



# SILOTOP<sup>®</sup> zero

SILO VENTING DUST COLLECTORS

# 2

## ASSEMBLY AND MAIN INSTRUCTIONS FOR USE AND MAINTENANCE



Manual No. FIL.253.--.M.EN Issue: A  
Latest Update: January 2017

ORIGINAL INSTRUCTIONS IN ENGLISH

**WAMGROUP S.p.A.**  
Via Cavour, 338  
I-41030 Ponte Motta  
Cavezzo (MO) - ITALY

☎ + 39 / 0535 / 618111  
fax + 39 / 0535 / 618226  
e-mail [info@wamgroup.com](mailto:info@wamgroup.com)  
internet [www.wamgroup.com](http://www.wamgroup.com)





**WAM**®

All the products described in this catalogue are manufactured according to **WAMGROUP S.p.A. Quality System procedures**. The Company's Quality System, certified in July 1994 according to International Standards **UNI EN ISO 9002** and extended to the latest release of **UNI EN ISO 9001**, ensures that the entire production process, starting from the processing of the order to the technical service after delivery, is carried out in a controlled manner that guarantees the quality standard of the product.

**This publication cancels and replaces any previous edition and revision.  
We reserve the right to implement modifications without notice.  
This catalogue cannot be reproduced, even partially, without prior written consent by the Manufacturer.**

**SUMMARY**

<b>1.0</b>	<b>GENERAL INFORMATION</b>	<b>1</b>
1.1	Scope of the Manual	1
1.2	Symbols	2
1.3	Glossary and terminology	4
1.4	Manufacturer's data and identification of equipment	5
1.5	Request for assistance	6
1.6	Warranty	6
1.7	Exclusion of responsibility	6
<b>2.0</b>	<b>INFORMATION REGARDING SAFETY</b>	<b>7</b>
2.1	General safety prescriptions	7
2.2	Safety prescriptions for transport and handling	7
2.3	Safety prescriptions for installation	8
2.4	Safety prescriptions for use and operation	8
2.5	Safety prescriptions for maintenance and replacement of components	8
<b>3.0</b>	<b>TECHNICAL INFORMATION</b>	<b>10</b>
3.1	General description of the equipment	10
3.2	Main components	11
3.3	Operating principle	12
3.4	Permitted use	12
3.5	Improper use not permitted	12
3.6	Noise level	13
3.7	Environmental operating limits	13
3.8	Overall dimensions and technical features	14
3.9	Safety and information signs	14
<b>4.0</b>	<b>INFORMATION REGARDING HANDLING AND TRANSPORT</b>	<b>15</b>
4.1	Type of packaging	15
4.2	Reception of goods	16
4.3	Lifting and unloading methods	16
<b>5.0</b>	<b>INSTALLATION AND FIXING</b>	<b>18</b>
5.1	Recommendations for installation	18
5.2	Positioning the dust collector flange	20
5.3	Installation - Emissions sampling kit	21
5.4	Electrical connection	23
5.5	Wiring diagram	26
5.6	Timers setting	27
5.7	Electronic control panel: MDPE setting (if provided)	29
5.8	Pneumatic connections	36
5.9	Inspection	39
5.10	Commissioning	39

<b>6.0</b>	INFORMATION REGARDING USE .....	40
6.1	Production start-up .....	40
6.2	Equipment shutdown at the end of the work cycle .....	40
6.3	Long shutdown of the equipment .....	41
6.4	Reuse .....	41
<b>7.0</b>	INFORMATION REGARDING MAINTENANCE .....	42
7.1	Cleaning the equipment (the machine) .....	42
7.2	Filter element cleaning .....	43
<b>8.0</b>	REPLACEMENT OF PARTS.....	44
8.1	Safety recommendations for replacement .....	44
8.2	Replacing the filter elements .....	44
8.3	Replacing solenoid valve .....	48
8.4	Returning the equipment (the machine).....	49
8.5	Dismantling and disposal .....	49
<b>9.0</b>	INFORMATION REGARDING FAULTS .....	50
9.1	Trouble-shooting .....	50
9.2	Check-list in case of fault .....	52
<b>10.0</b>	TECHNICAL DATA .....	53
10.1	Dimensions and weights .....	53
10.2	Filter elements.....	54
10.3	Cleaning system.....	55
10.4	Accessories - Bottom ring .....	56
10.5	Accessories - Emissions sampling connection kit .....	57

## 1.1 Scope of the Manual

This Manual has been prepared by the Manufacturer to provide the operating technical information for installation, operation and maintenance of the equipment concerned.

The Manual, which is an integral part of the equipment concerned, must be preserved throughout the life of the equipment in a known easily accessible place, available for consultation whenever required.

If the Manual is lost, damaged or becomes illegible, contact the Manufacturer for a copy specifying the serial number of the equipment.

If the equipment concerned changes ownership, the Manual has to be handed over to the new owner as part of the equipment supply.

The Manual is meant for specialist technical personnel appointed and authorized by the Manufacturer, owner and installer to act on the equipment concerned for which specific technical skills in the sector concerned are necessary (electrical, mechanical, etc.).

The illustrations may differ from the actual structure of the equipment concerned but do not interfere with the explanation of the operations.

In case of doubt, contact the Manufacturer for explanations.

The Manufacturer reserves the right to make changes to the Manual without the obligation to provide prior notification, except in case of modifications concerning the safety level.

The technical information included in this Instruction Manual is the property of the Manufacturer and therefore has to be considered as confidential.

It is forbidden to use the Manual for purposes other than those strictly linked to the operation and maintenance of the equipment concerned.

This information is provided by the Manufacturer in the original language (English) and can be translated into other languages to satisfy legislative and/or commercial requirements.

## 1.2 Symbols

To highlight certain parts of the text, for purposes of safety, or to indicate important information, certain symbols are used, the meaning of which is described below.

It is important to comply with and scrupulously follow the information highlighted by the symbols.



### **Danger - Warning**

**Indicates situations of serious danger which, if ignored, can be risky for the health and safety of persons.**



### **Caution**







**Indicates that appropriate behaviour must be adopted to avoid posing risk for the health and safety of persons and avoid causing economic damage.**



### **Important**

**Indicates particularly important technical information which must not be ignored.**

List of safety and information symbols

Symbol representation	Symbol description
	<p><b>Danger sign:</b> indicates danger of electric shock caused by the presence of powered components inside the junction box or control panel.</p>
	<p><b>Obligation:</b> read this Manual before carrying out any action on the equipment concerned.</p>
	<p><b>Forbidden:</b> indicates that it is forbidden to lubricate or adjust moving parts.</p>
	<p><b>Danger:</b> indicates danger of serious injury to limbs if the internal moving parts of the equipment are exposed. Before opening inspection or maintenance hatches or doors isolate the equipment concerned from the electrical energy sources.</p>
	<p><b>Information:</b> indicates the direction of rotation of the electric motor.</p>
	<p><b>Obligation:</b> indicates the hooking points for lifting each section of the equipment concerned.</p>
	<p><b>Forbidden:</b> indicates it is forbidden to introduce hands into the equipment.</p>

### 1.3 Glossary and terminology

**Operator:** person appropriately trained and authorized by the Production Manager for setting up the equipment concerned and carrying out routine maintenance.

**Installer:** organization with specialized technicians and appropriate equipment for carrying out risk-free installation and extraordinary maintenance.

**Specialist technician:** person responsible for and authorized by the Manufacturer, owner or installer to act on the equipment; must have specific technical skills depending on the sector concerned (electrical, mechanical etc.). The specialist technician, in addition to being familiar with the working of the equipment concerned, must be familiar with the working of the plant or equipment on which the equipment concerned is installed.

**Routine maintenance:** includes all the actions necessary to keep the equipment in good working conditions, to ensure greater operating durability and to keep the safety requisites constant.

**Extraordinary maintenance:** all the actions meant to keep the equipment in perfect working order.

**Setting in safety conditions:** all the precautions the authorized personnel must adopt before acting on the equipment concerned.

The precautions are listed below.

- Ensure that the equipment concerned is disconnected from all the mains and appropriate devices are used to prevent these from being reconnected accidentally.
- Ensure that all the moving parts of the equipment have come to a complete stop.
- Ensure the temperature of the equipment concerned is such that it does not burn.
- Provide appropriate lighting in the area around the operations.
- Wait for the material to be handled inside the equipment or machine concerned to settle down completely.



1.4 Manufacturer's data and identification of equipment



Important

**Do not change the data on the identification plate.  
 Keep the ID plates clean, intact and legible as regards the data they contain.  
 If the ID plate is damaged or is no longer legible (even just one informative element on it) contact the Manufacturer for a new ID plate and replace it.**

The ID plates shown identify the equipment concerned and its main components.  
 The plates show the reference necessary for operating safety.

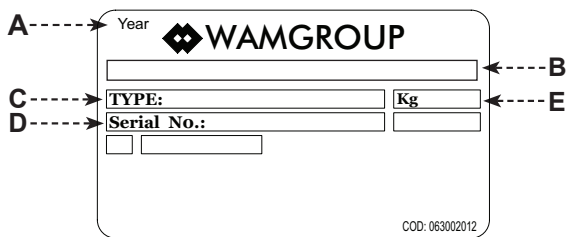
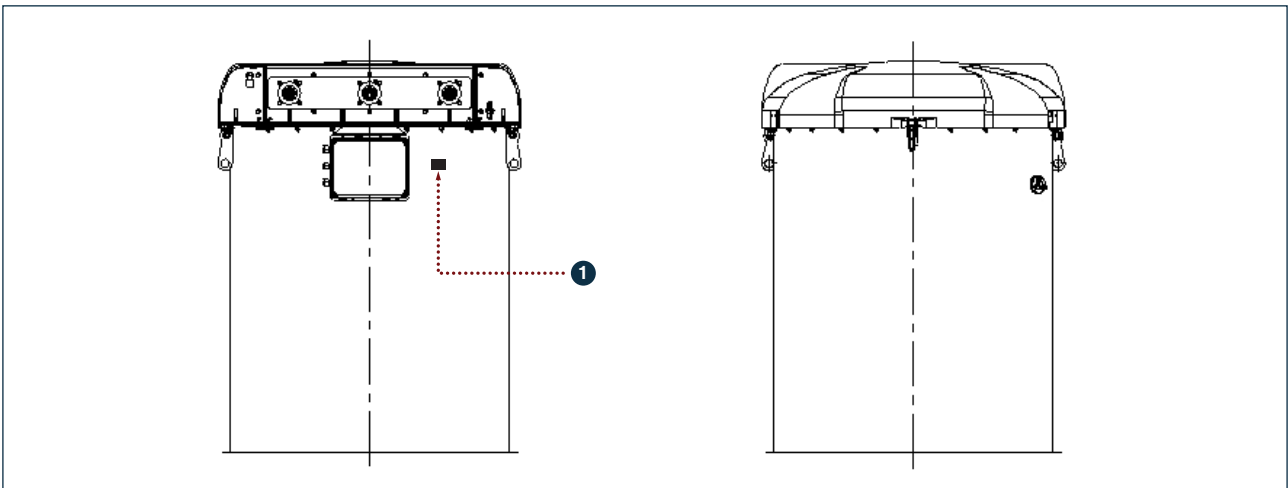

**1 - Identification plate of equipment**

- A) Year of manufacture
- B) Manufacturer's name and address
- C) Type of equipment
- D) Serial No.
- E) Weight of the equipment

### 1.5 Request for assistance

For all technical assistance, contact the Manufacturer's service network.

For all requests, provide the equipment identification data, the type of problem encountered and all other information which could be useful for identifying the problem.

### 1.6 Warranty

The conditions for validity and applicability of the warranty are specified in the sales contract.

### 1.7 Exclusion of responsibility

The equipment is delivered according to the specifications indicated by the Buyer in the order and the conditions valid at the time of purchase.

The Manufacturer shall not accept responsibility for safety of persons or objects and operation failure of the equipment if the loading/unloading operations from trucks, transport, positioning at the site, use, repairs, maintenance etc. have not been carried out in compliance with the warnings described in this Manual, and in accordance with the national legislation in force.

Likewise, the Manufacturer shall not accept any responsibility if the equipment concerned is used:

- improperly;
- by unauthorized persons and/or persons not sufficiently trained for installation, operation and maintenance;
- with modifications made to the original configuration without the Manufacturer's permission;
- with spare parts that are not original or are not specific for the model;
- without maintenance;
- non-pursuant to the regulatory standards and national or local legislation on the matter of occupational safety;
- non-pursuant to the recommendations in this Manual or on the warning and danger plates applied on the equipment.

## 2.1 General safety prescriptions

Read the Instruction Manual carefully and strictly follow the instructions it includes, especially those regarding safety.

Most accidents at the workplace are caused by negligence, failure to follow the most elementary safety regulations and incorrect or improper use of tools and equipment.

Accidents can be prevented and avoided by taking due care, using suitable equipment and adopting adequate preventive measures.

Apply and comply with the standards in force regarding workplace hygiene and safety.

The personnel trained for and authorized for the operations has to have the psychological/physical requisites, experience in the sector concerned and the necessary technical skills for carrying out the operations assigned to them.

All workers involved in any kind of operation must be prepared, trained and informed as regards the risks and the behaviour to be adopted.

Pay attention to the meaning of the notices applied on the equipment, keep these legible and respect the information indicated.

Use instruments, equipment and tools that have been approved and are intrinsically safe, and cannot alter the safety level of the operations or damage the equipment during installation, use and maintenance.

Modifications to the equipment components should not be made for any reason whatsoever, without the Manufacturer's permission.

## 2.2 Safety prescriptions for transport and handling

Carry out all the handling and transport operations in accordance with the procedures and instructions shown on the packaging and in the Manual supplied.

All the operations must be performed by qualified authorized personnel.

Those authorized to carry out the handling operations must have the capabilities and experience required to adopt all the necessary measures to guarantee one's safety and the safety of persons directly involved in the operations.

The chosen features of the lifting and handling means (crane, bridge crane, forklift truck etc.) must take into account the weight to be handled, the dimensions and the gripping points.

During lifting use only accessories such as eyebolts, hooks, shackles, spring hooks, belts, slings, chains, ropes etc., that have been certified and are suitable for the weight to be lifted.

During handling respect the prescriptions applicable for handling loads.

Keep the position of the equipment concerned or the sections and the loose components horizontal, keep the load low and make all the necessary movements gently.

Avoid sudden manoeuvres, dangerous oscillations and rotations, accompanying the movements manually and place the load gently on the ground.

### 2.3 Safety prescriptions for installation

Before starting with installation, a “Safety Plan” must be implemented to safeguard the personnel directly involved and those who carry out operations in the surrounding area.

All the laws must be strictly applied, especially those concerning workplace safety.

Before proceeding with installation operations, mark off the work area to prevent access by unauthorized persons.

The electrical connections must be made in compliance with the standards and laws in force.

The person in charge of making the electrical connections has to ensure that the required standards and laws are respected before testing.

### 2.4 Safety prescriptions for use and operation

Do not tamper with the equipment concerned by using any kind of device to obtain performances different from those designed.

All unauthorized changes can affect the health of people and the integrity of the equipment.

The operators have to exclusively wear protective clothing and have to be equipped with appropriate individual protection devices for carrying out the operations and as required by the safety and work accident prevention standards.

Before use, ensure that all the safety devices are installed and that they are working properly.

During operations, prevent access to the work area by unauthorized persons.

Remove all obstacles or sources of danger from the work area.

It is strictly forbidden to walk or placing any improper load on the equipment.

### 2.5 Safety prescriptions for maintenance and replacement of components



#### **Danger - Warning**

**Before carrying out any operation on the equipment concerned, ensure it is switched off and disconnected from all mains and use suitable devices to prevent the possibility of the power sources being activated accidentally.**

Maintain the equipment concerned in the conditions of utmost efficiency compliant with the maintenance plan provided by the Manufacturer.

Good maintenance apart from preserving the functional features and essential safety features over time, will also allow extending the working life of the equipment concerned and achieving the best possible performance.

Strictly follow the procedures indicated in the Manual, especially those concerning safety.

Ensure that all the safety devices are active and working properly.

Mark off the work area in such a manner as to prevent the access of unauthorized persons.

Replace the worn and damaged components exclusively with original spare parts, whose safety, reliability and interchangeability have been undoubtedly established.

## 2.0 INFORMATION REGARDING SAFETY

**Apart from invalidation of the warranty, the Manufacturer declines all responsibility for damage to objects and harm to persons deriving from the use of non-original spare parts or due to modifications made during repairs without express written authorization.**

**Use the oil and lubricants recommended by the Manufacturer.**

**Do not dump polluting material (oil, grease, paint, plastic etc.) in the environment, but carry out waste separation disposal depending on the chemical composition of the various products in compliance with the legislation in force.**

**On completion of maintenance or replacement operations, before resuming production, check that no foreign bodies (rags, tools etc.) have been left inside the equipment concerned.**

### 3.1 General description of the equipment

**SILOTOP® zero** is a cylindrically shaped dust collector for venting of pneumatically filled silos.

The stainless steel body contains vertically mounted **POLYPLEAT®** filter elements. The air jet cleaning system is integrated in the hinged weather protection cover.

Dust separated from the air flow by **POLYPLEAT®** drops back into the silo after an integrated automatic pulse-jet cleaning system inside the weather protection cover has removed it from the filter elements.

**SILOTOP® zero** is designed for being integrated with other systems in the context of a plant in order to obtain a clearly defined application.



#### Important

**The terms “equipment”, “filter” used in this manual refer to the same machine.**

**As components meant for installation in a plant, the filters - not fully provided with safety means - have to be considered “partly completed machinery”. Therefore, they do not bear an EC marking.**

**It is forbidden to start the equipment unless the machine/plant in which it is to be installed has been declared compliant with the Directive 2006/42/EC and further modifications.**

### 3.2 Main components

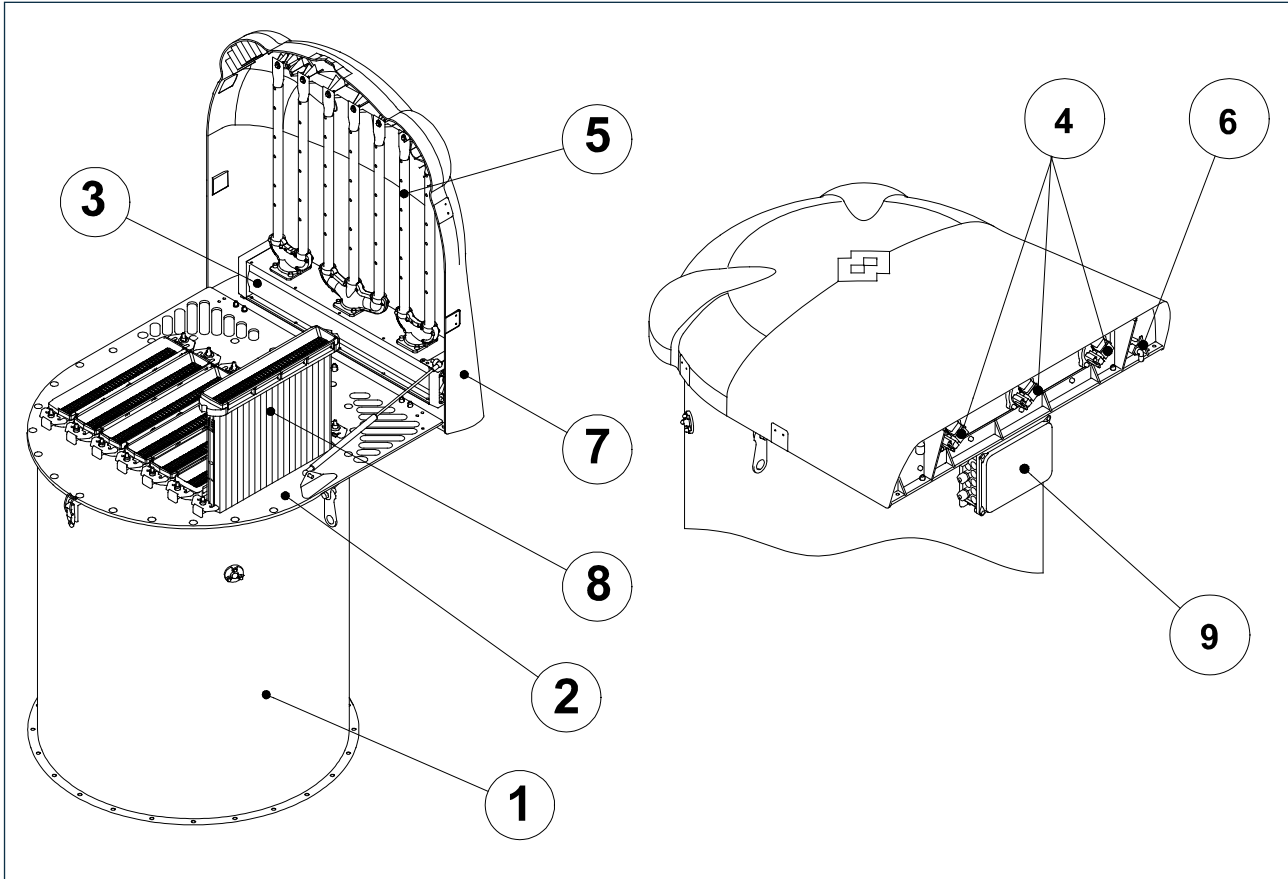

- |                    |                                      |
|--------------------|--------------------------------------|
| 1) Filter body     | 6) Condensation drain cock           |
| 2) Seal frame      | 7) Filter cover                      |
| 3) Air tank        | 8) <b>POLYPLEAT®</b> filter elements |
| 4) Solenoid valves | 9) Electronic timer                  |
| 5) Blow pipes      |                                      |

### 3.3 Operating principle

The dirty air enter the dust collector body (1) where dust is separated by the filter elements (8).  
Dust drops back into the silo after an automatic pulse-jet cleaning system (3+4+5) has removed it from the filter elements.

### 3.4 Permitted use

The **SILOTOP<sup>®</sup> zero** dust collector filter has the function of separating dust particles conveyed by a air flow or gas, using filtering elements made of non-woven polyester fabric.

The dusty air flow crosses the filter, which is able to stop the dust particles, allowing the air flow over it.

The dust collected on the filter elements surface is periodically removed by the compressed air jet cleaning system.

**Every other use must be considered as improper and therefore not permitted.**

### 3.5 Improper use not permitted

The dust collector must not be used as an element for discharging overpressure inside closed volumes. One or more blow-off valves must always be provided in the plant to keep the pressure level within the filter resistance limits.

The air flow handled by the dust collector must never exceed the value defined in the order phase.

Using the dust collector when the components (filter elements, cleaning system, fan, if present, etc) are not in perfect conditions can cause harm to persons and to the environment.

Do not start operating the dust collector until the plant or equipment in which it is to be incorporated has been declared as conforming to the relevant national and local legislative provisions in force.

It is forbidden to use the dust collector in potentially inflammable or explosive atmospheres (ATEX).

It is forbidden to use the dust collector for inflammable (magnesium powder, etc.) or explosive products.

It is forbidden to use the dust collector for products that can cause bacteriological contamination.



### 3.6 Noise level

The noise level of the **SILOTOP<sup>®</sup> zero** series dust collector does not exceed the limit of the directive 86/188/CEE and 89/392/CEE.

The measured equivalent continuous A-weighted sound pressure level LAeq is 70.0 dB(A).

All readings were taken at 1 metre distance from the equipment at 1.6 metres from ground, with compressed air shots at 6 bar each 28 seconds, using a precision sound level meter.

Noise measurements of installed equipment may vary due to site conditions.



#### **Danger - Warning**

**Depending on the installation site, the installer must adopt suitable systems (barriers, etc.), if necessary, to maintain the noise levels within the limits permitted by law.**

### 3.7 Environmental operating limits

Unless otherwise specified, the equipment concerned may be used only within the limits indicated.

- Altitude: less than 1,000 m at sea level
- Environmental temperature: between - 20 °C and + 40 °C
- Cold climates: with temperature less than 5 °C use oil and lubricants suitable to the operating temperature.

### 3.8 Overall dimensions and technical features

For an exact identification of the equipment concerned, see the identification plate.  
 The shipping documents show the Serial number and identification codes.  
 The information regarding the technical features of the equipment is given in Chapter 10.

### 3.9 Safety and information signs



#### Danger - Warning

**Respect the signs on the plates.**  
**Ensure that the plates are readable; otherwise clean them and replace the damaged ones, placing them in their original position.**

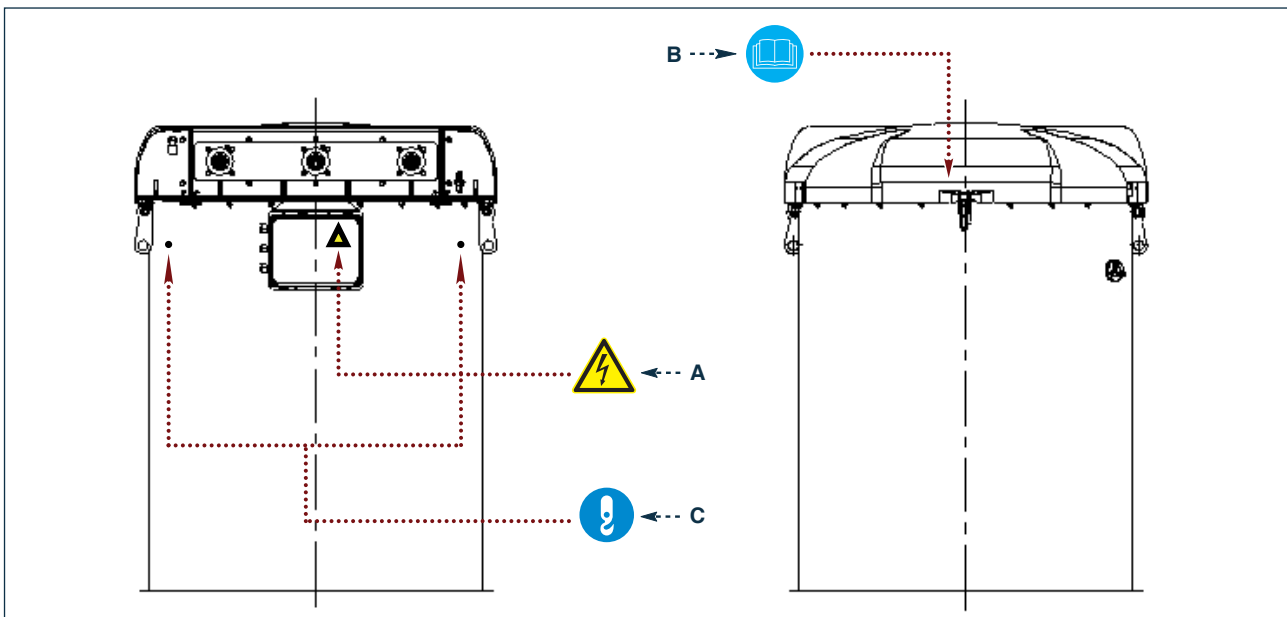

- A) Danger sign:** indicates danger of electric shock because of powered components present inside the junction box.
- B) Obligation:** read this Manual before carrying out any action on the equipment concerned.
- C) Obligation:** indicates the hooking points for lifting each section of the equipment concerned.

### 4.1 Type of packaging

The filter is supplied on a pallet and protected with a wooden crate.

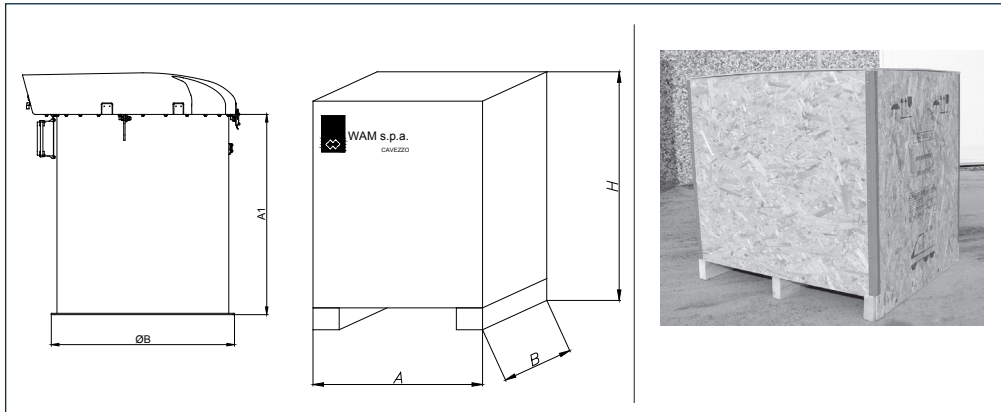

	Ø B	A1	A	B	H	WEIGHT WITH WOODEN CRATE (KG)
<b>SILAB14</b>	837	914	1000	1100	1300	115
<b>SILAB24</b>						122

dimension in mm

The signs for safe lifting and handling are shown on all packages.

**A) Fragile:** indicates that the package has to be handled and lifted carefully to avoid damage.



**B) Centre of gravity:** indicates the position of the gravity centre of the package.



**C) Harness:** indicates the correct harness position for lifting the package.

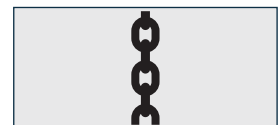

**D) Stacking limit:** indicates the maximum stacking load of the packages.



**E) Weight:** indicates the maximum weight of the package.



The packaging material has to be disposed off or recycled in compliance with the standards in force.

## 4.2 Reception of goods

On receiving the goods, ensure that the type and quantity correspond to the data present on the acknowledgement of order.

Possible damage has to be immediately communicated in writing in the space provided to this purpose in the waybill.

The carrier is obliged to accept the complaint and leave the Customer a copy of the waybill.

If the supply is “free destination” a copy of the waybill and of the complaint shall be sent to the Manufacturer or to the forwarder.

If the damages are not claimed immediately on receipt of the goods, your request for compensation may not be accepted.

## 4.3 Lifting and unloading methods



### **Danger - Warning**

**Carry out the lifting and handling operations according to the information indicated on the equipment and in the Manufacturer's Operation Manual.**

**The person authorized for unloading operations has to make sure all the necessary measures are adopted to ensure his or her safety and the safety of other persons directly involved.**

**Use means and accessories (ropes, hooks, shackles etc.) suitable for the load to be lifted.**

**Pay attention in the lifting phase to balance the load to avoid uncontrolled movements which could cause work injuries to persons.**

**Do not stack the packages as they are not sized for that purpose.**

**Do not drag or push the entire or sections of the equipment as it will damage them.**

**Before lifting and handling the load, read the relevant information indicated in the “Information regarding safety” Chapter.**

Harness the packages according to the indications and symbols applied on them or harness the sections of the equipment concerned on the basis of their structure.

The illustration shows the equipment lifting points according to the configurations envisaged.

## 4.0 INFORMATION REGARDING HANDLING AND TRANSPORT

### *Lifting the dust collector*

The dust collector should only be handled and lifted using the eye-bolts provided. Use lifting devices suitable to the weight and dimensions of the dust collector and to the lifting distances concerned. Connect the dust collector to the lifting device using shackle and safety hooks; do not use clamps, rings, open hooks or any other system that does not ensure the same safety degree as shackles and safety hooks.

### *Lifting device*

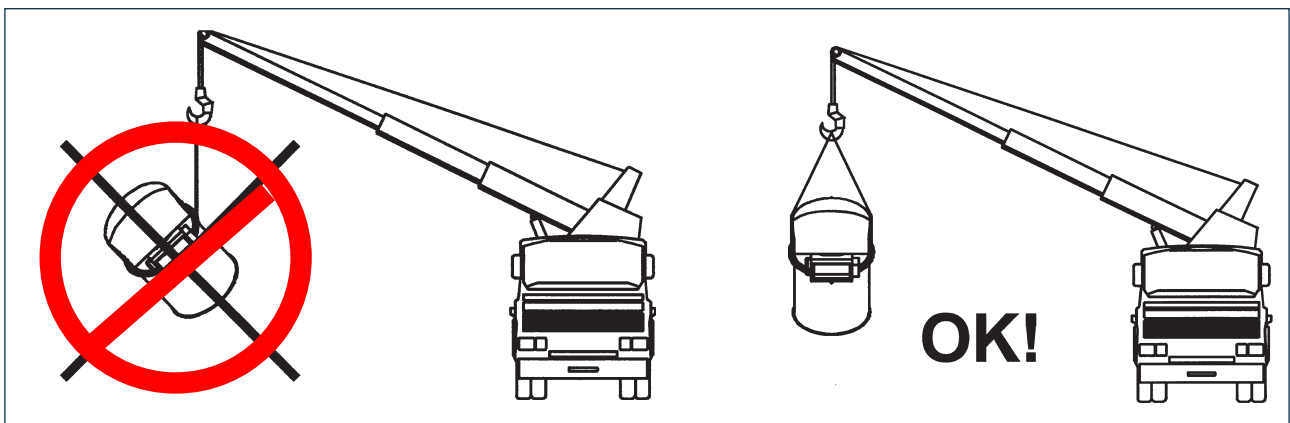

Unload the packages from the means of transport and place them on a flat surface which can ensure stability.

## 5.1 Recommendations for installation



### Danger - Warning

The installation operations have to be carried out by a technician specialized in such activities. Provide appropriate safety measures and use suitable equipment to prevent risk of work accident to persons involved in the operations and to those nearby. Harness and handle the sections of the equipment concerned as described and shown in the “Unloading and lifting method” paragraph.

Before starting installation, define a safety plan compliant with the standards in force regarding workplace safety.

The specialist technician, authorized by the installer or owner, has to evaluate whether the area has been properly prepared and whether the necessary installation equipment is available (crane, etc.).

Define, on the basis of the configuration of the equipment concerned, the assembly method.

Check, and if damaged, repair the coupling surfaces.

Clean the surfaces thoroughly.

### General principles

*Assembling on silo*

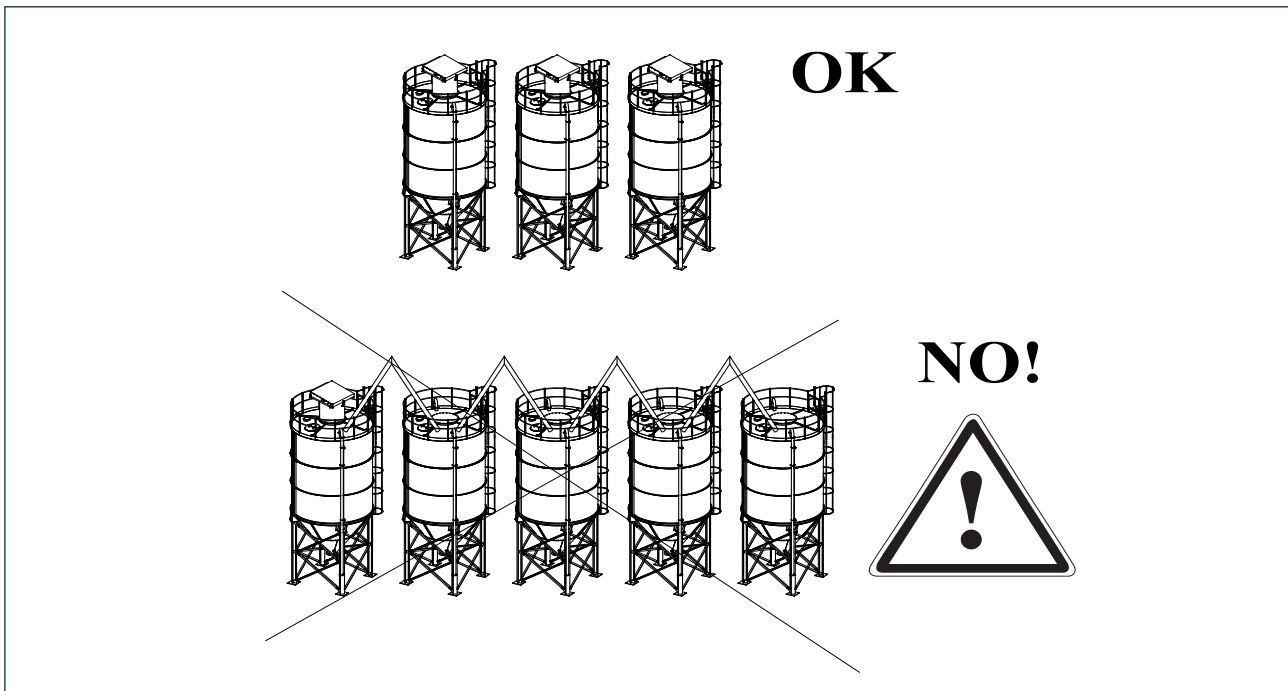

## 5.0 INSTALLATION AND FIXING

The equipment supplied is provided with perimeter gasket to be inserted between the dust collector and the bottom ring, and the fastening nuts and bolts.

Tighten the bolts by applying a tighten torque of 10 Nm.

### Gasket

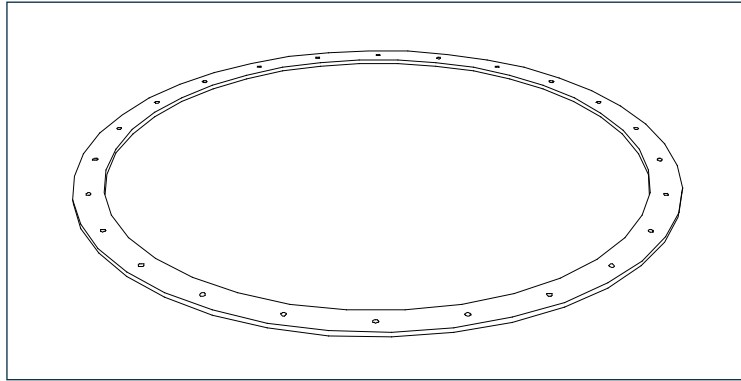

### Gasket positioning

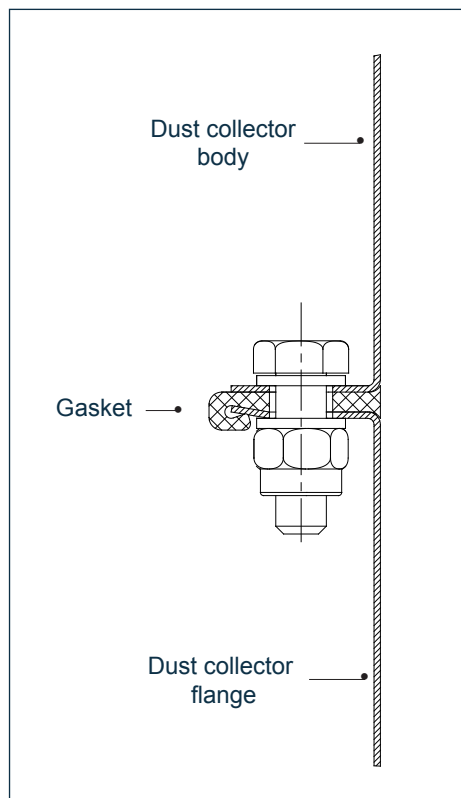

**5.2 Positioning the dust collector flange**

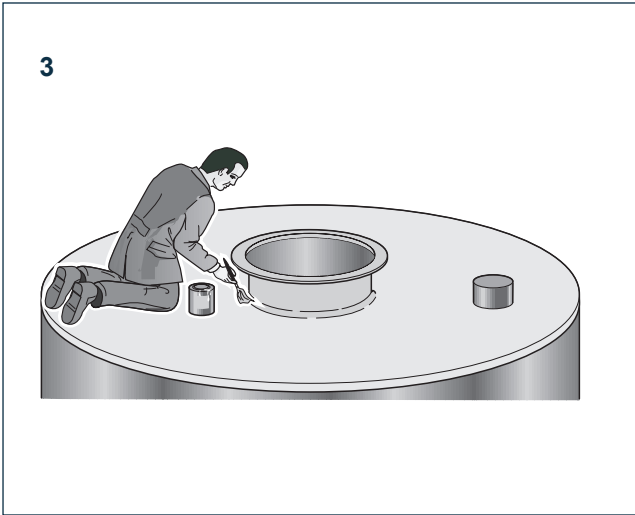
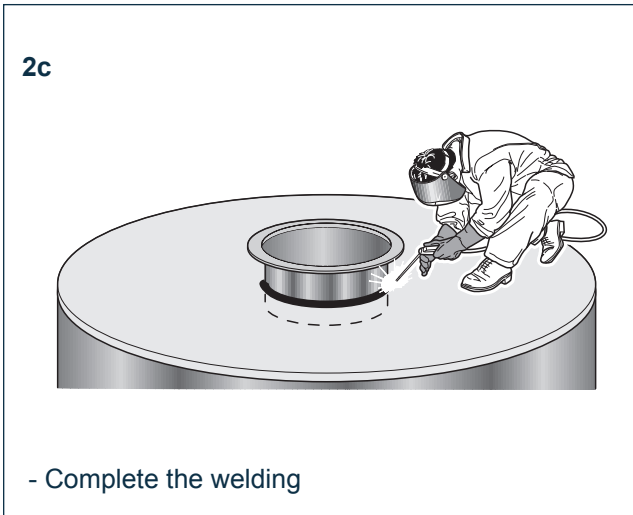
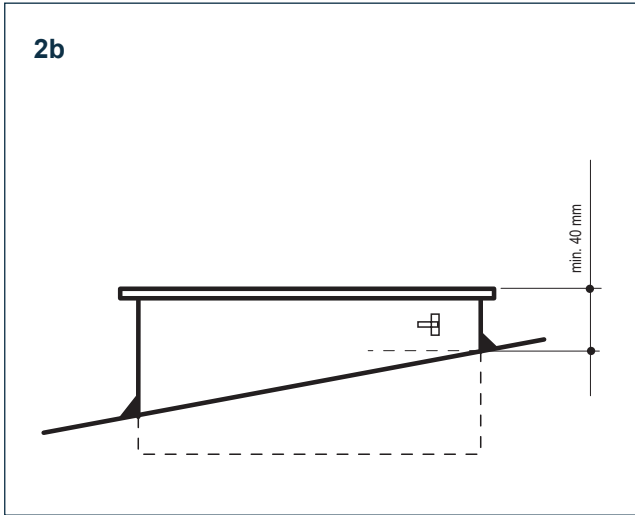
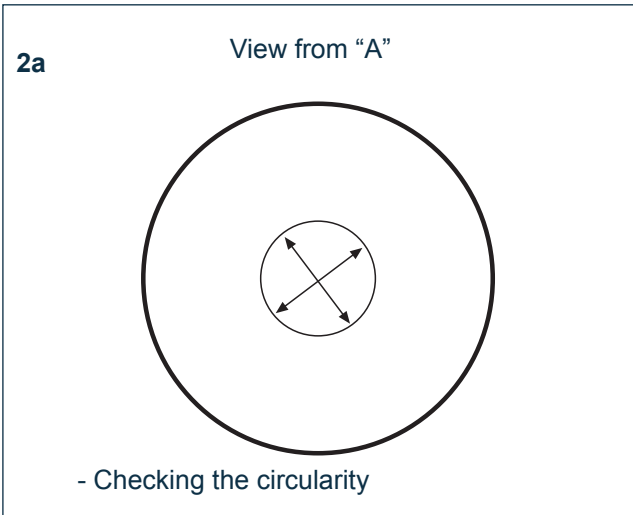
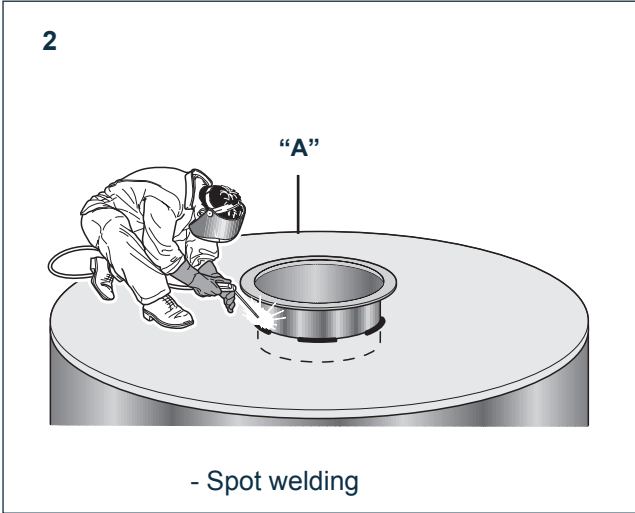



5.3 Installation - Emissions sampling kit

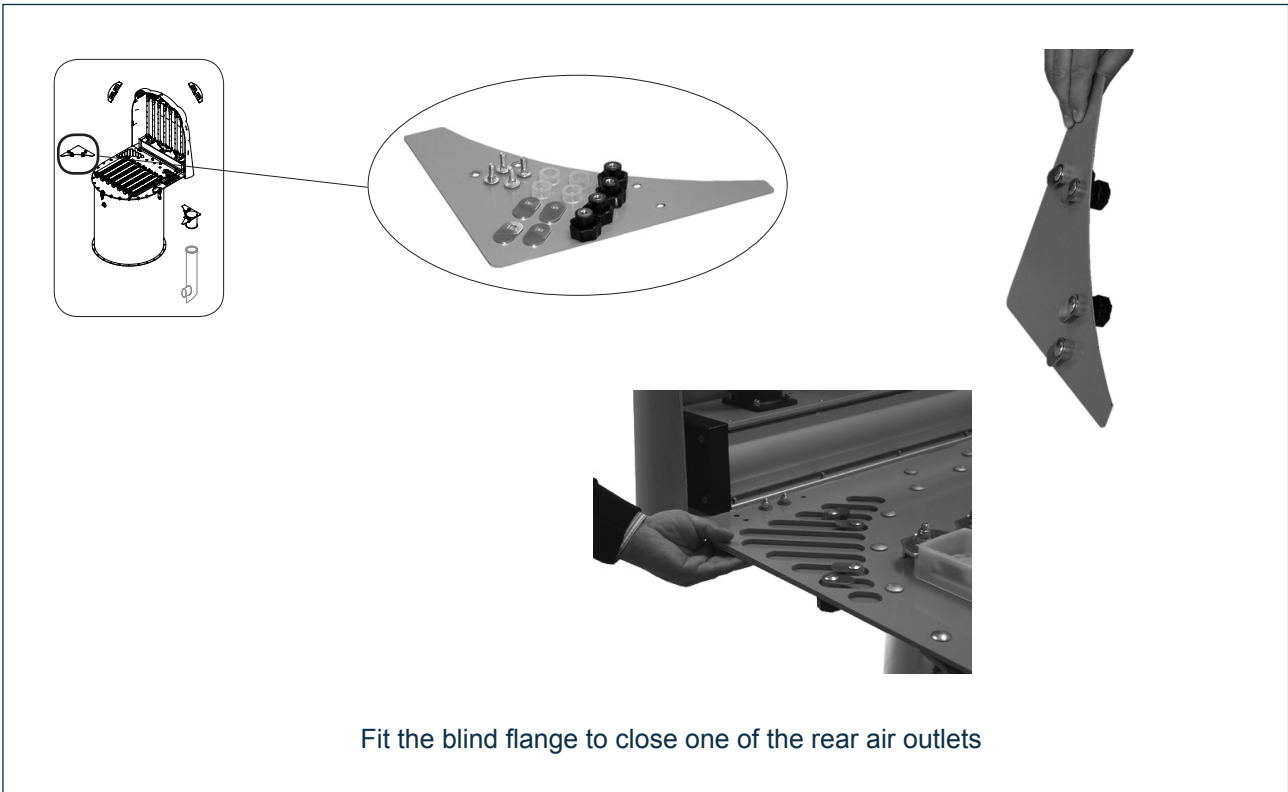
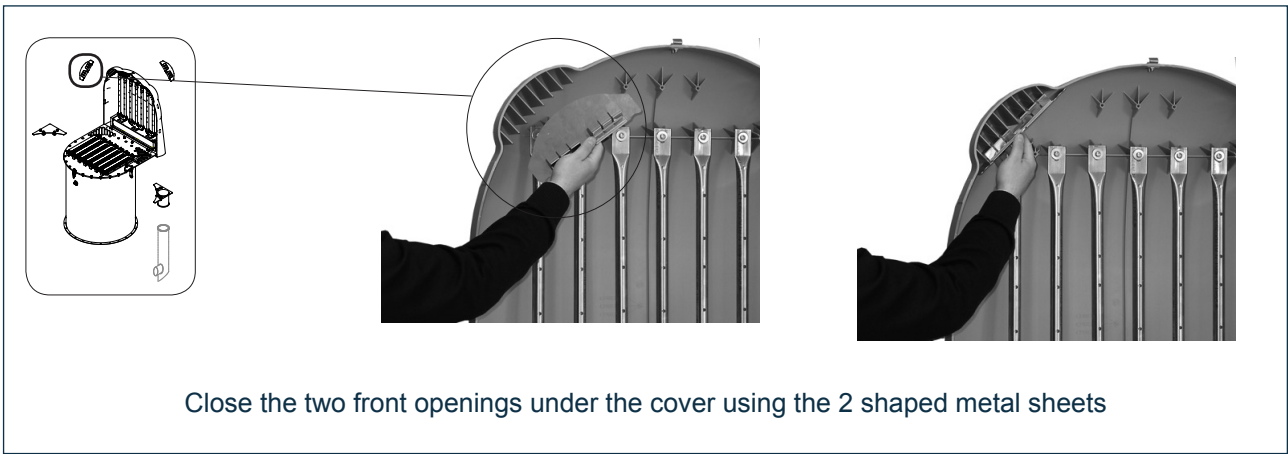

5.0 INSTALLATION AND FIXING

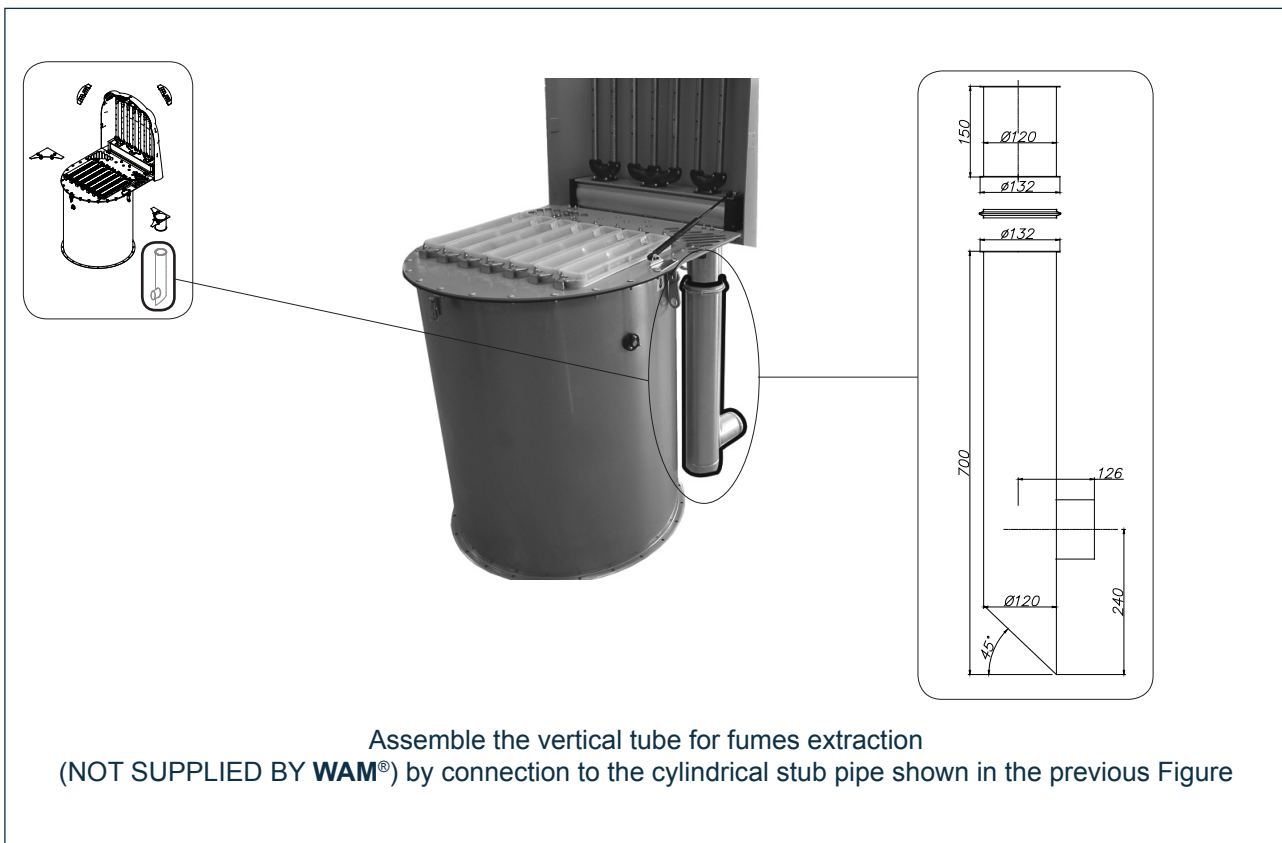
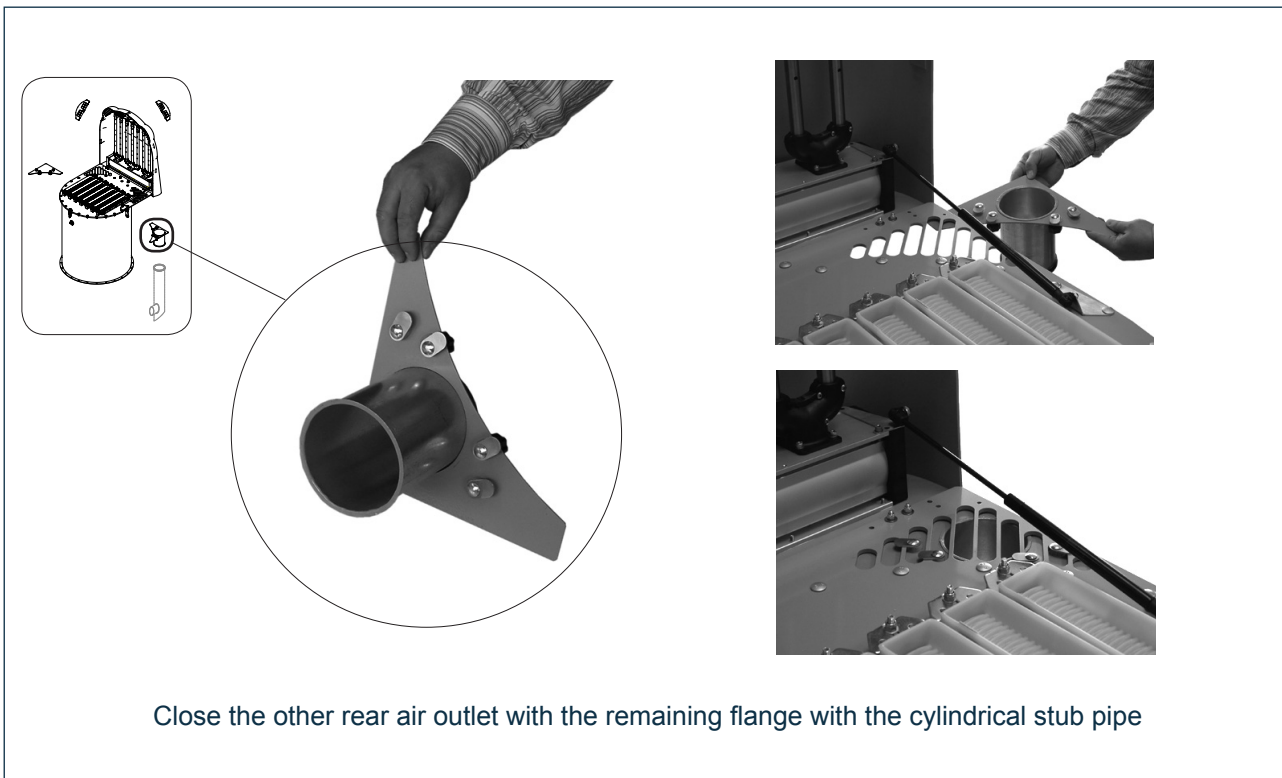

## 5.4 Electrical connections



### Danger - Warning

**The equipment is not provided with an electrical system. Connection to the mains has to be carried out by an electrician.**

**Provide mains supply to the equipment concerned according to the compliant current legislation and take into consideration the safety measures required by the installation environment and the envisaged operating conditions.**

**Before carrying out the connection ensure that the mains voltage and frequency correspond to those indicated on the electric motor rating plate.**

**Disconnect from the mains before carrying out any work and use suitable devices so that there cannot be an accidental reconnection.**

Use electric cables having cross section appropriate to the power absorption of the equipment concerned.

The installer will have to provide to interfacing the equipment with the necessary controls: start/stop, emergency stop, reset after an emergency stop, in compliance with the regulatory standards in force.

Disconnect the mains before each intervention and use suitable devices to prevent an accidental reconnection of the equipment.

Ensure that the protection devices are present and working each time the equipment is started up.

The installer must connect the equipment to the earthing system of the plant.

For **SILOTOP® zero** dust collectors, the control board is located inside a box with IP66 protection in accordance with Standard CEI EN 60529. The board is supplied prewired: the connections to the coils are made and tested by **WAM®**. The standard supply includes the microswitch for adjustment of the pause times (time between one “cleaning shot” and the next) as well as that for adjustment of the “cleaning” time (solenoid valve opening time); the adjustable times are shown in the “Timers settings” section (5.6).

All the control panels are provided with a fixed timer used to end the cleaning cycle. It is known that the most effective cleaning of every dust removal system is the one carried out with no air at the filter inlet. In absence of an ascending air flow, the dust detaches from the elements more easily, leaving the fabric cleaner.

*Electronic control panel connection*

- 1) **POWER SUPPLY VOLTAGE** - Works with all the supply voltages from 24V to 260V either in AC or in DC.
- 2) **SUPPLY VOLTAGE AUTO-RECOGNITION** - The electronic panel automatically recognises the voltage applied, therefore no settings are necessary for normal operation.
- 3) **CONNECTIONS TO JUNCTION BOX** - The electronic panel is powered by means of terminal (S1) and accepts all the voltages mentioned at point 1) above. To switch on the control panel a clean contact (voltage free) must be connected to the terminal strip S2. When the contact (S2) opens, the end of cycle cleaning system begins and continues for a fixed period of about 10 minutes, during which the preset pause and cleaning times are maintained.
- 4) **WAIT SAFETY BLOCK** - Activation of the WAIT input (closure of contact) suspends the cleaning cycle and saves the position of the last output activated. The block persists as long as WAIT is active (contact closed). When WAIT is deactivated (contact open), the cleaning cycle is resumed from the next output to the last output energized if S2 is still active. Otherwise, the program returns to STANDBY without carrying out the end of cycle cleaning system. The WAIT contact can be used as safety/alarm switch or to reduce the end of cycle cleaning system duration. In fact, if WAIT is activated during the end of cycle cleaning system, the cleaning stops completely; if WAIT is deactivated, the program returns to STANDBY.

*Control panel electrical input*

The Table of power inputs of the panel in various operating conditions, i.e. according to the supply voltage is shown below.

POWER SUPPLY VOLTAGE (VAC)	POWER INPUT (A)	POWER (W)
24	0.220	5.3
115	0.090	10.4
230	0.050	11.5
260	0.045	11.7

**Important**

**The main power supply (S1) must always be present on the panel (deactivate only for maintenance).**

	TIMER SETTING						
	PAUSE (sec)			WORK (sec)			END OF CYCLE CLEANING SYSTEM (min)
	MIN.	MAX.	SET	MIN	MAX	SET	FIXED TIME
SILAB14	5	90	56	0.1	0.3	0.1	10
SILAB24			39				

5.0 INSTALLATION AND FIXING

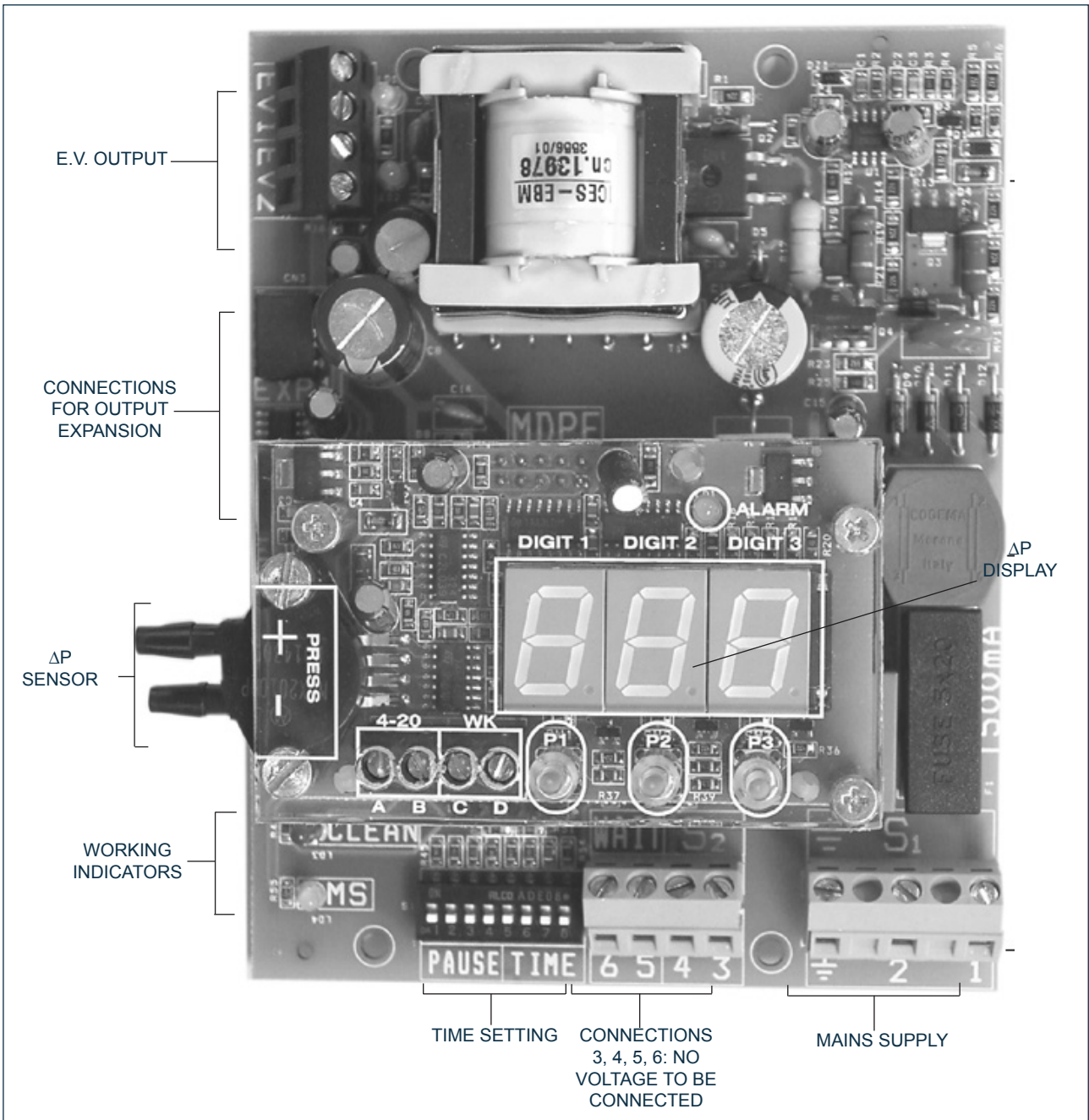

The picture shows the MDPE module (optional)



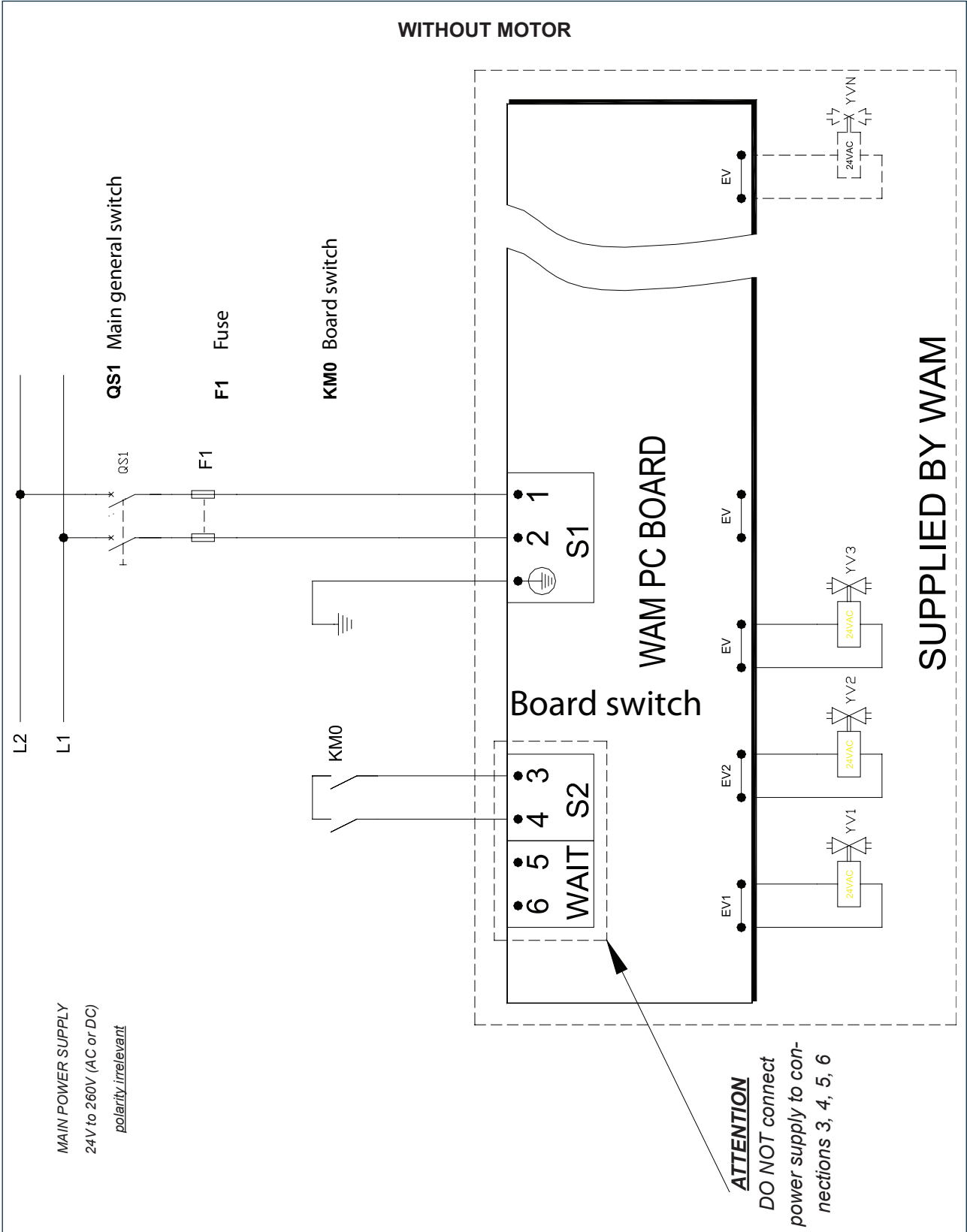

5.5 Wiring diagram



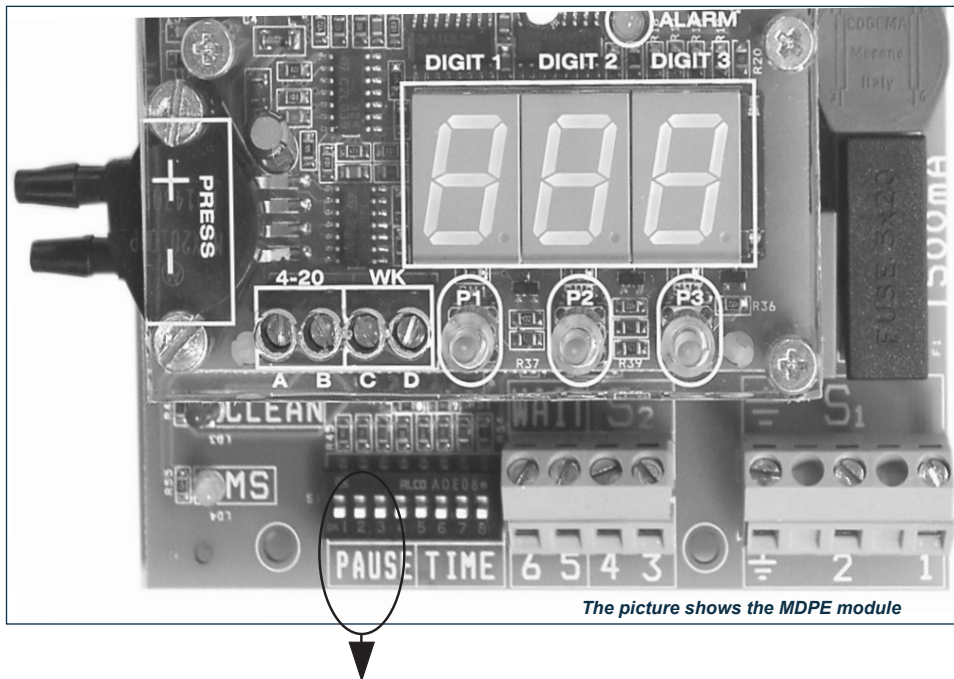

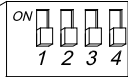
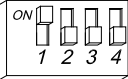
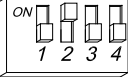
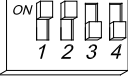
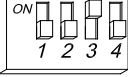
**5.6 Timers setting**
*Pause time*

The preset pause time can be modified by acting on the microswitch provided for the purpose in the following way:

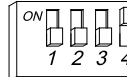
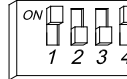
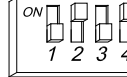
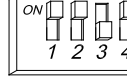
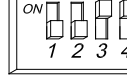

**MICROSWITCH 1**

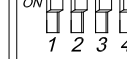
	PAUSE TIME
	5
	11
	16
	22
	28
	33
	39
	45

	PAUSE TIME
	50
	56
	62
	67
	73
	79
	84
	90

**Work time**

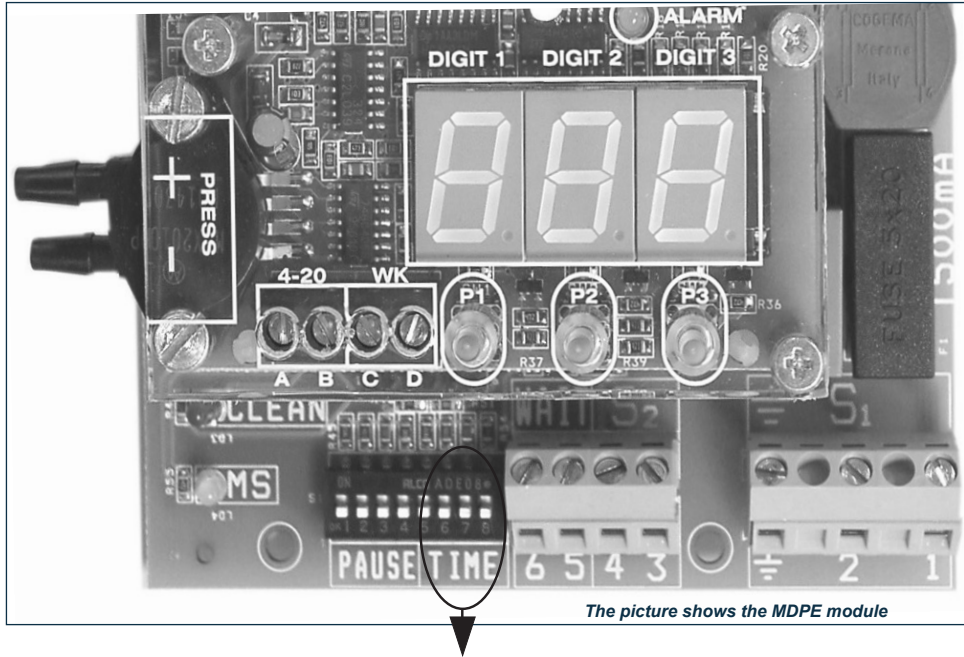
The preset work time can be modified by acting on the microswitch provided for the purpose in the following way:

**MICROSWITCH 2**

WORK TIME		PRESET VALUE FOR CARTRIDGES	WORK TIME	
	0.1			0.21
	0.11		0.22	
	0.13		0.23	
	0.14		0.25	
	0.15		0.26	
	0.17		0.27	
	0.18		0.28	
	0.19		0.3	



### 5.7 Electronic control panel: MDPE setting (if provided)

#### Operating principle

When connected electrically and mechanically to the control panel, the MDPE reads the pressure differential value between the 2 inputs of the transducer and displays it in millimetres of water column on a 3-digit display. At the same time the value indicated is transmitted proportionally to the 4-20 mA analog output.

#### Enabling timer panel operation

If the MDPE panel is set to control the timer panel, the pressure differential measuring device will prevent the working of the cycles until the pressure read by the transducer reaches the preset **activation value** (upper threshold). The flashing display will indicate the enabling. Once the cycle is enabled, the MDPE will disable it when the pressure measured drops below the preset **deactivation value** (lower threshold). The display no longer flashes.



#### Danger - Warning

**The activation threshold cannot be set lower than the deactivation threshold.**

#### Operating and programming mode

The programming system consists of three keys P1, P2 and P3 and the 3-digit display. The P1, P2 and P3 keys can be used to display a certain parameter, modify the value and save the setting.

The functions that can be associated with the pressing of individual keys or combinations of keys are listed in the following Tables:

#### Operating mode

OPERATING MODE	
FUNCTION	KEYS TO BE PRESSED
DEACTIVATION PRESSURE	P <sub>1</sub>
ACTIVATION PRESSURE	P <sub>2</sub>
T <sub>WORK</sub>	P <sub>3</sub>
T <sub>PAUSE</sub>	P <sub>1</sub> +P <sub>2</sub>
ENTER PROGRAMMING PROCEDURE	P <sub>2</sub> +P <sub>3</sub>

PROGRAMMING MODE	
DOWN	P <sub>1</sub>
UP	P <sub>2</sub>
ESC	P <sub>1</sub> +P <sub>3</sub>
ENTER	P <sub>2</sub> +P <sub>3</sub>

During normal operation, the **MDPE** panel displays the pressure value measured in real time. Pressing **P1** (DOWN) in this situation will display the preset **deactivation value** (pressure value at which the MDPE deactivates the cleaning cycle), while pressing **P2** (UP) will display the preset **activation value** (once reached this pressure level the MDPE activates the cleaning cycle).

**5.0 INSTALLATION AND FIXING**

The operating time (TIME) can be displayed by pressing **P3** and the pause time (PAUSE) can be displayed by pressing **P1** and **P2**. In the diagram below is indicated the combination of keys to be pressed to proceed to the next stages.

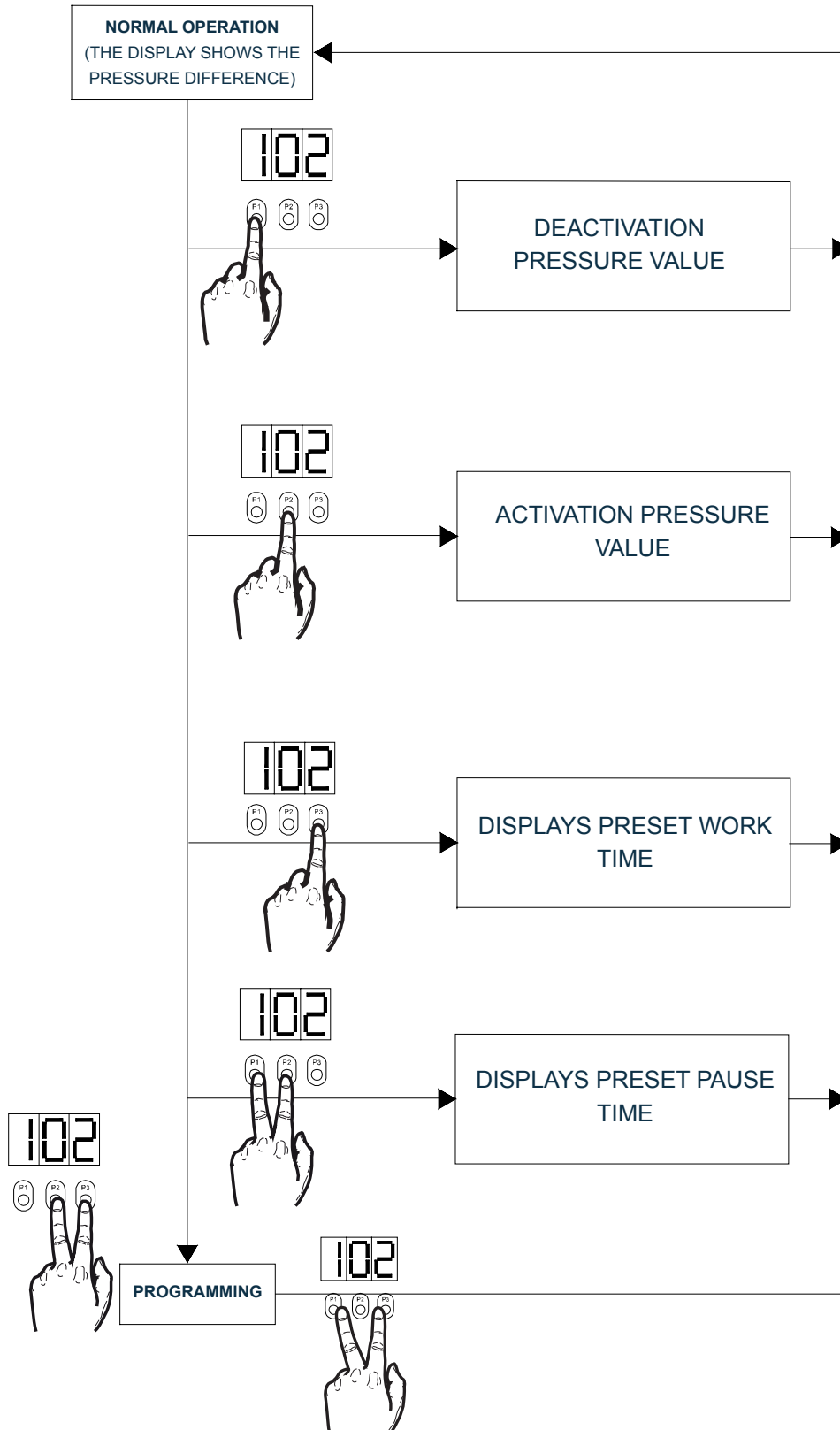

**5.0 INSTALLATION AND FIXING**
*Programming mode*

The programming procedure is activated by pressing **P2** and **P3** (ENTER) simultaneously. On pressing the keys the LH digit on the display will show an identification number (from 1 to 8) relative to the parameter being examined (see table), while the two remaining ones or just the last one, to the RH, indicates the value selected for that parameter.

At this point **P1** (UP) or **P2** (DOWN) can be pressed to scroll through the functions that can be set (the LH digit, indicating the parameter flashes). Once the parameter to be modified has been identified, keep **P2** and **P3** (ENTER) pressed to enter the mode for programming the parameter concerned (the two digits to the RH (DIGIT2 and DIGIT3) or only the last to the RH -DIGIT3- flash, while the digit to the LH indicating the parameter stops flashing). At this point, use **P1** (UP) and **P2** (DOWN) to scroll through the possible options for that parameter.

Press keys **P2** and **P3** (ENTER) to store the parameter value modified. When **P1** and **P3** (ESC) are pressed, the modifications are not saved. Both operations end the parameter programming and return to the menu preceding parameter selection. Pressing **P1** and **P3** again will end the program and bring about return to normal operating mode.

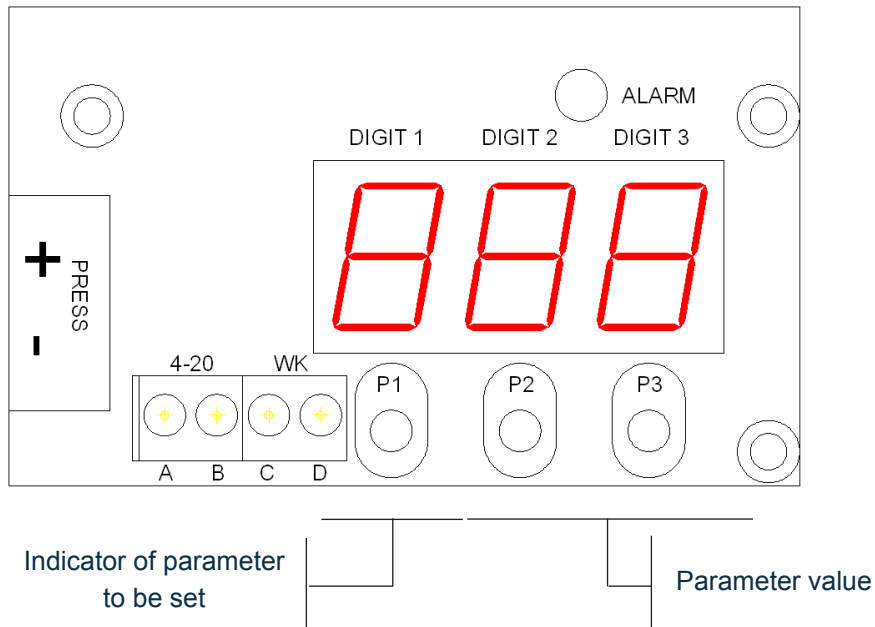

5.0 INSTALLATION AND FIXING

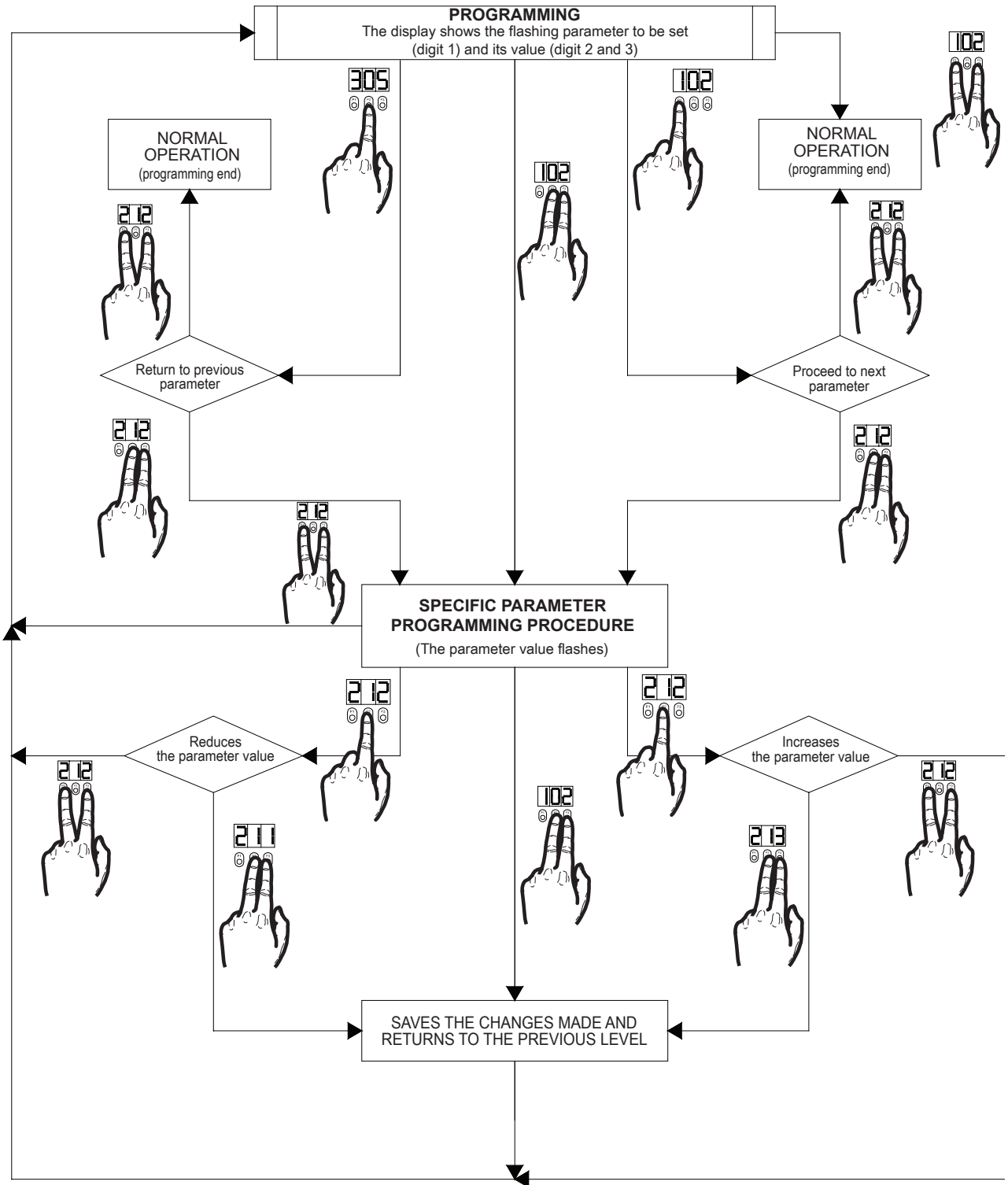

On entering the programming mode eight values of the first digit can be selected. Each of these represents a different parameter. The description of the function related to each parameter is given below.

- 1) **MDPE OPERATING MODE:** Modify parameter 1 to set the MDPE operating mode. The MDPE operating modes are 2 (two):
- MDPE activate and deactivate the control board and the cleaning system, too;
  - MDPE just provide the pressure value reading.

**Important**

**It will not be possible to set an activation pressure lower than the deactivation pressure already set. If necessary first modify the deactivation pressure.**

- 2) **ACTIVATION PRESSURE:** The activation pressure can be set from a minimum of 10 to a maximum of 500 mm of water column (10-500mm H<sub>2</sub>O) in steps of ten. On the display, the mm of water column is set in tens in the two digits to the right (Digits 2 and 3), i.e., the required pressure value divided by ten is set.

**Important**

**It will not be possible to set a deactivation pressure higher than the activation pressure already set. If necessary first modify the activation pressure.**

- 3) **DEACTIVATION PRESSURE:** The deactivation pressure can be set from a minimum of 10 to a maximum of 500 mm of water column (10-500 mm H<sub>2</sub>O) in steps of ten. On the display, the mm of water column is set in tens in the two digits to the right (Digits 2 and 3), i.e., the required pressure value divided by ten is set.
- 4) **ALARM PRESSURE:** If the programmable output has been set to indicate that the alarm pressure value has been reached and the pressure measured has reached the value indicated in this parameter, the system must activate the programmable output till the alarm ceases. The relative green LED will remain switched on as long as the value remains above the threshold value. The alarm value can be preset from a minimum of 10 to a maximum of 500 mm of water column (10-500 mm H<sub>2</sub>O) in steps of ten. On the display, the mm of water column is set in tens in the two digits to the right (DIGIT 2 and 3), i.e., the required pressure value divided by ten is set.
- 5) **UNUSED FIELD**
- 6) **PROGRAMMABLE OUTPUT:** By means of the programming procedure it is possible to select the type of indication of the programmable output among the following:
- Output activated by the activation of the cleaning system (when the cleaning system is ON the output is activated);
  - Output activated by the alarm pressure (when the pressure reach the alarm pressure the output is activated). The related green LED will remain ON. This is an Open output type with driving loads (relays) of 24V DC with maximum power input of 200 mA.

**7) INTERNAL PARAMETERS FOR THE SETTING**

If necessary, use the following programming procedure to set the zero of the instrument.

5.0 INSTALLATION AND FIXING

- a) Make sure there is no air flow through the filter.
- b) Disconnect both hose pipes from the outside of the controller board casing (part A).
- c) Enter module settings mode of field 7 of the MDPE and set the value to 1.
- d) Save the value (**P3+P2**).
- e) Exit the module settings mode and read value XX in DIGIT2 and DIGIT3 on the display.
- f) Return to module settings mode and set field 7 to value XX.
- g) Save the value (**P3+P2**) and exit module settings mode (**P3+P1**).
- h) Reconnect the hose pipes to the controller board casing in the correct position (clean chamber tube of the filter to the RH (-), foul air chamber tube of filter to the LH (+)).

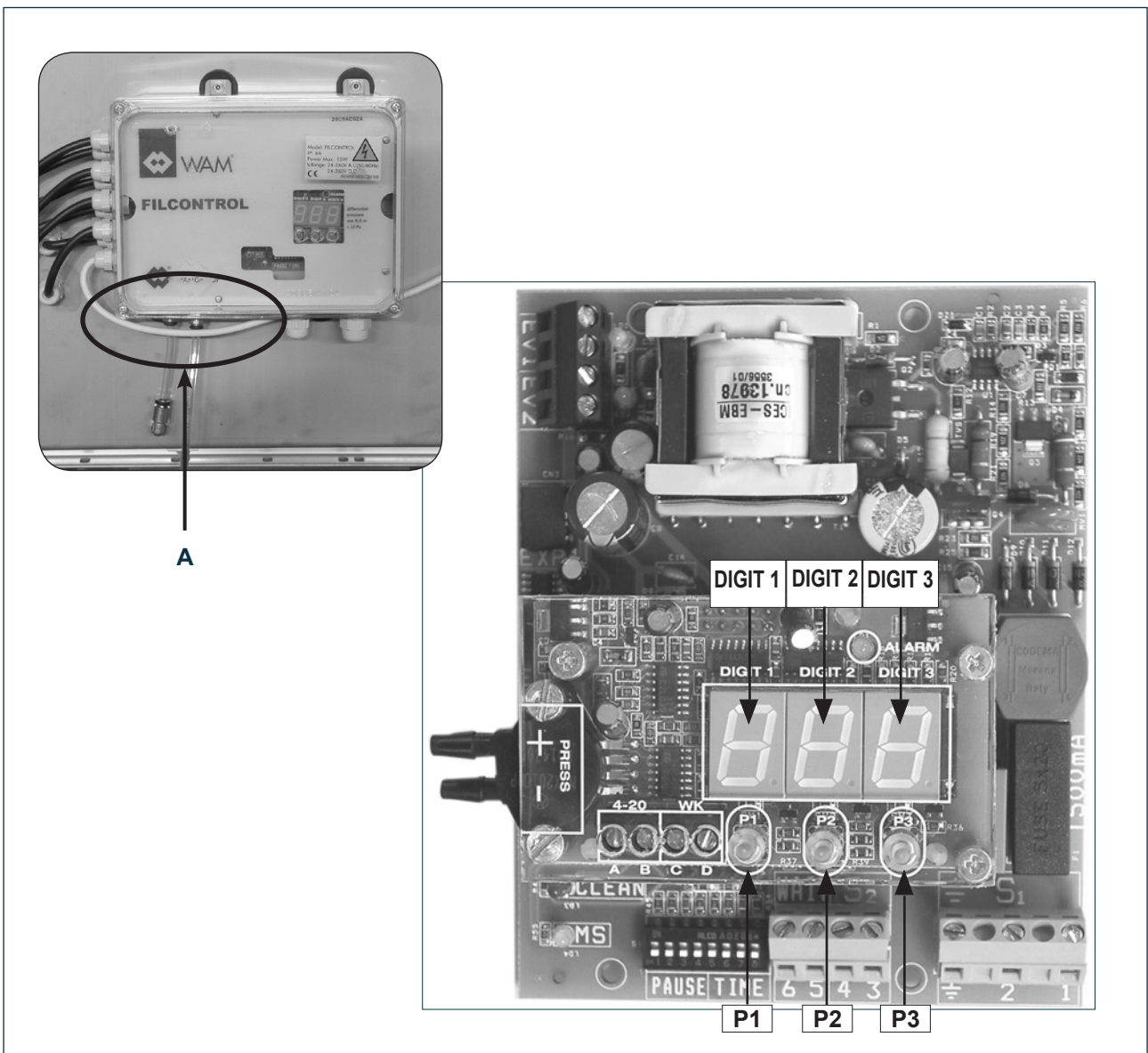

**5.0 INSTALLATION AND FIXING**

PARAMETER FUNCTION	DIGIT 1	DIGIT 2	DIGIT 3	STATUS
MDPE OPERATING MODE	1		1	MDPE activate and deactivate the control board and so the cleaning system
			2	MDPE just provide the pressure value reading.
ACTIVATION PRESSURE	2		1	Preset value 10 mm H <sub>2</sub> O
			2	Preset value 20 mm H <sub>2</sub> O
			3	Preset value 30 mm H <sub>2</sub> O
		4	9	Preset value 490 mm H <sub>2</sub> O
		5	0	Preset value 500 mm H <sub>2</sub> O
DEACTIVATION PRESSURE	3		1	Preset value 10 mm H <sub>2</sub> O
			2	Preset value 20 mm H <sub>2</sub> O
			3	Preset value 30 mm H <sub>2</sub> O
		4	9	Preset value 490 mm H <sub>2</sub> O
		5	0	Preset value 500 mm H <sub>2</sub> O
ALARM PRESSURE	4		1	Preset value 10 mm H <sub>2</sub> O
			2	Preset value 20 mm H <sub>2</sub> O
			3	Preset value 30 mm H <sub>2</sub> O
		4	9	Preset value 490 mm H <sub>2</sub> O
		5	0	Preset value 500 mm H <sub>2</sub> O
----	5	--	-	Field not used
PROGRAMMABLE OUTPUT	6		1	Output activated by the activation of the cleaning system (when the cleaning system is ON the output is activated)
			2	Output activated by the alarm pressure. (when the pressure reach the alarm pressure the output is activated)
INTERNAL PARAMETERS	7	4	2	INTERNAL SETTINGS NOT TO BE MODIFIED
INTERNAL PARAMETERS	8	6	4	INTERNAL SETTINGS NOT TO BE MODIFIED

**PRESET VALUES TABLE**

PARAMETER FUNCTION	PRESET VALUE
MDPE OPERATING MODE	2
ACTIVATION PRESSURE	90 mm H <sub>2</sub> O
DEACTIVATION PRESSURE	40 mm H <sub>2</sub> O
ALARM PRESSURE	400 mm H <sub>2</sub> O
PROGRAMMABLE OUTPUT	2

## 5.8 Pneumatic connections

### *Compressed air requirements*

The operation of the filter requires permanent connection to a compressed air circuit. The compressed air must be:

- 1) **Clean** - Free of waste which could damage the filter solenoid valves
  - 2) **De-humidified** - The filter tank is provided with a condensation drainage cap. It is recommended to provide for a condensation separator.
  - 3) **Oil-free** - The presence of oily substances in the air could cause premature and irreversible clogging
- Use filters which always keep the air clean and oil-free.



### **Danger - Warning**

**Discharge the piping before connecting the compressed air supply to the filter.**

### *Tank inlet pressure*

- Minimum 4 bar
- Maximum 6 bar

Variations of the usage conditions may require:

- Modifications of inlet pressure to the tank
- Modifications to the control board settings, that requires changing the compressed air consumptions.

It is recommended to install a Kit (pressure gauge, relief valve) near the filter. A manual cut-off device (ball valve or similar device) must be inserted on the line to facilitate subsequent maintenance operations.



### **Important**

**The filter must be supplied with a separate branch that can be disconnected independently.**

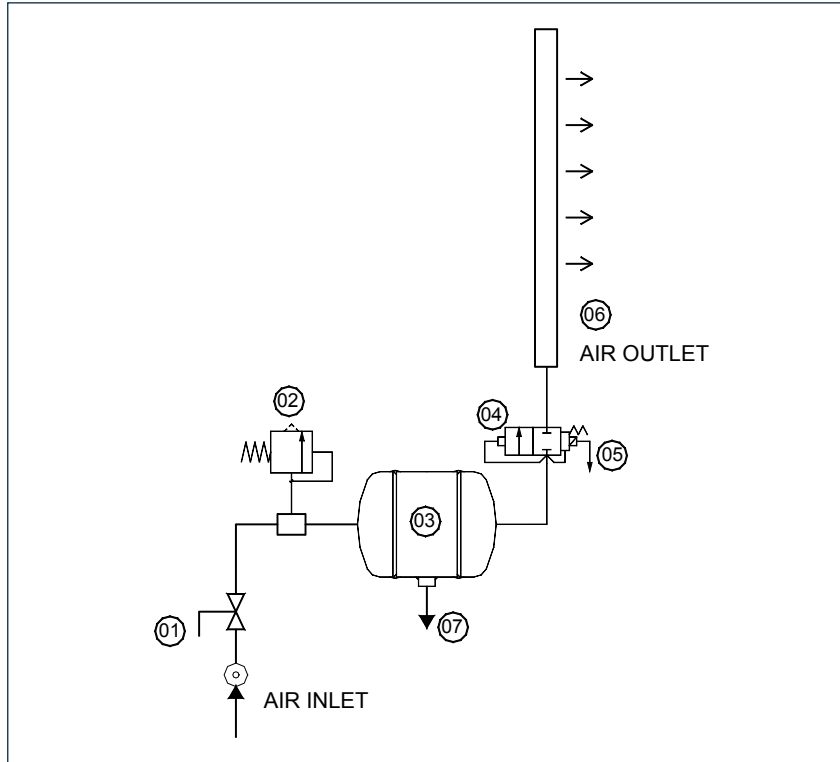

**5.0 INSTALLATION AND FIXING**

CODE	DESCRIPTION
01	MANUAL BALL VALVE (NOT SUPPLIED BY <b>WAM®</b> )
02	RELIEF VALVE (NOT SUPPLIED BY <b>WAM®</b> )
03	TANK
04	1" RAPID DISCHARGE VALVE
05	COIL
06	AIR OUTLET
07	CONDENSATION DRAINAGE

**5.0 INSTALLATION AND FIXING**

The compressed air coupling on the filter is achieved by means of a push-in fitting (for 12 mm pipe). The installer must fix the compressed air hose pipes correctly and provide the due protections against sudden detachment of the pipes.

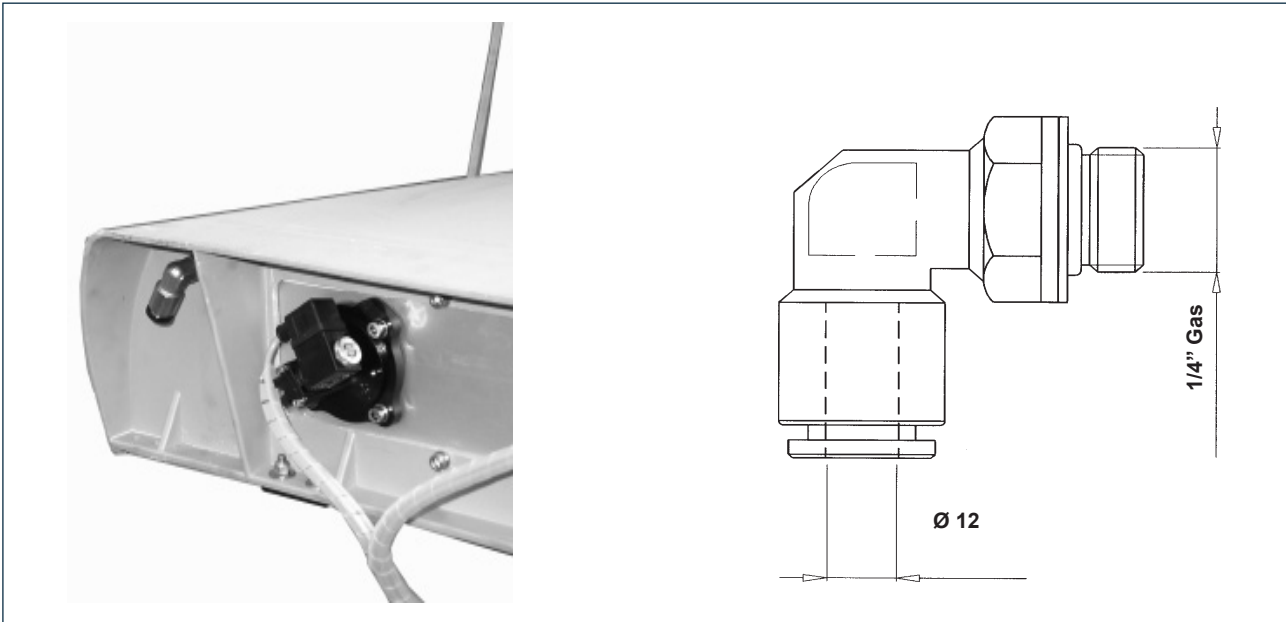
**COMPRESSED AIR CONSUMPTION**

	AIR TANK VOLUME	P (bar)	PULSE DURATION	CLEANING INTERVAL	Nm/h
SILAB14	5	4	0.1	56	1.8
SILAB24				39	2.5

## 5.9 Inspection



### Important

**When installation is complete, authorized personnel must carry out a general test to ensure that the safety conditions have been completely satisfied.**

The authorized personnel must also check:

- that no tools or other material have been forgotten inside the filter;
- that the fixing screws have been tightened using the prescribed torque;

Before starting to operate the filter:

- Ensure that the plant in which the filter is installed is compliant to the Directive 2006/42/EC and to the relevant general directives and safety standards in force and those specifically applicable.
- Ensure that the inspection hatches are locked with the bolts supplied inserted in their original position.
- Ensure that the operating conditions are met.

## 5.10 Commissioning

### *Preliminary checks*

After completing the electrical and compressed air connections, carry out the following checks:

- Check to ensure the controller board is powered and set correctly.
- Ensure that the pressure of the filter reservoir is 6 bar.
- Check all nuts, bolts and locking devices to ensure they are perfectly tightened.
- Check all elements to ensure they are fixed properly to the seal frame.
- Check the seals to ensure they are not damaged and the inspection hatch is closed.
- Ensure that the warning and instruction signs are present.
- Check piping connections to the filter (if these are present) to ensure they are secured and assembled carefully.

## 6.1 Production start-up

Before starting up the filter, the operator in charge and authorized for the production must ensure that the safety devices installed are present, in working order and that the operating conditions are respected (hatches closed, inlet and outlet).

### *Start-up procedure*

Proceed as follows (after preliminary checks):

- 1) Start up the dust discharger (if present)
- 2) Start up the air compressor.
- 3) Start up the control panel (MS LED ON).
- 4) Start up the cleaning cycle (clean LED ON)
- 5) Check all solenoid valves to ensure they work correctly (the yellow LED goes on when the board sends the impulse to the solenoid valve)
- 6) Check the cleaning cycle duration and the pause time.

Frequent checks of the filter operation **particular during the first few weeks** are essential.

Only through these checks it will be possible to determine whether the preset pause duration is the proper one as regards the cleaning of the filter cartridges.



### Important

**In case of excessive noise, strong vibrations, etc. stop the filter cleaning system and report the problem to the person in charge authorized to restore the correct working.  
Do not use the equipment if damaged.**

## 6.2 Equipment shutdown at the end of the work cycle

- 1) Switch off the filter without disconnecting from the mains (according to the wiring diagram instructions inserted in the panel, the timer is automatically activated for further after-shut-down cleaning cycle of 10 minutes).
- 2) After other 10 minutes, disconnect the controller from the mains.
- 3) Switch off the compressor.
- 4) Switch off the dust discharger valve or screw conveyor (if present).

### 6.3 Long shutdown of the equipment

When the filter remains unused for long periods, proceed as described below.

- 1) Avoid damp and salty environments during equipment shutdowns.
- 2) Place the equipment on wooden pallets and store it protected from inclement weather conditions.
- 3) Set the equipment in safety condition before operating it.
- 4) Before using the equipment, check the condition of the electrical and pneumatic systems and all the parts the working of which may be affected by prolonged shutdowns.
- 5) Run a complete cleaning cycle before activating the filter.

### 6.4 Reuse



#### Important

**If the equipment is to be used in different conditions and with materials other than the previous application, ensure the “Permitted use” indications are complied with.**

Before reusing the filter after a long shutdown, proceed as described below.

- 1) Check the main nuts and bolts to ensure they are tightened properly.
- 2) Start up the equipment (see “Production Start-up”).

**Danger - Warning**

**Before carrying out any maintenance activity, activate all the safety devices to ensure the safety of the persons involved in the operations and those near by.**  
**Set the equipment concerned in safety condition (see 2.0 Information regarding safety).**  
**Wear suitable personal protection equipment; in this regard, consult the person in charge of production activities safety.**

**- Scheduled maintenance Table**

Component	Operation to be carried out	Daily	Every month	Every six months	Every two years	Manual reference
Safety devices	Performance check	•				
Inspection hatches	Checking the condition	•				
Flanged assembly	Checking the seal	•				
Air tank	Checking the pressure and condensation		•			
Filter elements	Checking the state of the filter media and differential pressure		•			
Compressed air	Checking value and presence		•			
Control panel	Checking the condition			•		
Solenoid valve	Checking the functioning and condition			•		
Blowing pipes	Checking the condition				•	

**7.1 Cleaning the equipment (the machine)**

Clean the outside part of the equipment (the machine) using a vacuum cleaner to prevent dispersal of dust in the environment and in the surrounding area; or use a moist cloth.

Do not use compressed air.

Wash the equipment (the machine), after vacuuming the dust, with a low-pressure water jet.

## 7.2 Filter element cleaning

### POLYPLEAT<sup>®</sup>

The filter elements are made of non-woven fabrics based on polyester coated with special surface treatment. During maintenance they can be cleaned thoroughly to increase durability. The regeneration can be performed simply by mechanical shaking or using compressed air taking care to vacuum the dust generated by this operation.



### **Danger - Warning**

**Do not use water or high water-pressure cleaners.**

## 8.1 Safety recommendations for replacement



### **Danger - Warning**

The replacement operations must be carried out by a specialist authorized technician with specific skills in the sector concerned (mechanical, electrical etc).

Before carrying out any operation, provide suitable safety measures and use the appropriate equipment to prevent risk of work injuries to persons involved in the operations and those nearby.

Activate all the safety devices envisaged and prevent access to controls which, if activated, could cause work injuries to the persons involved in the operations.

## 8.2 Replacing the filter elements

Replace the filter elements with new ones having the same structural and functional features. Always ask for original spare parts to ensure the safety and functionality of the equipment.

*Disassembly*



### **Danger - Warning**

**Set the filter in safety condition (see glossary and terminology).**

**Do not drop the filter elements**



**OPEN THE FILTER COVER**

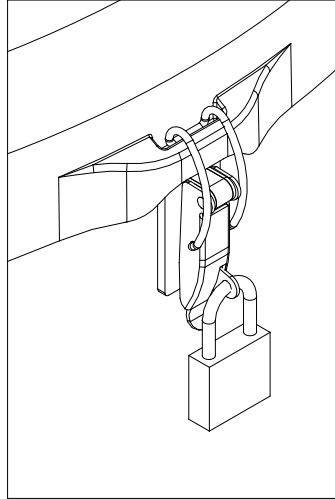

Remove the padlock.

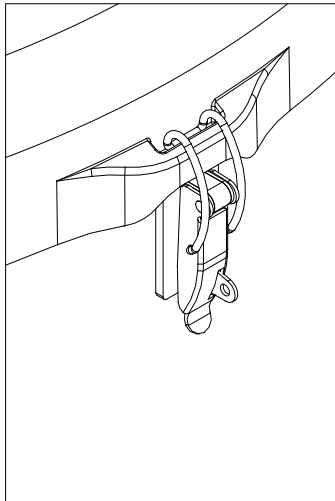

Open the snap lock.

8.0 REPLACEMENT OF PARTS

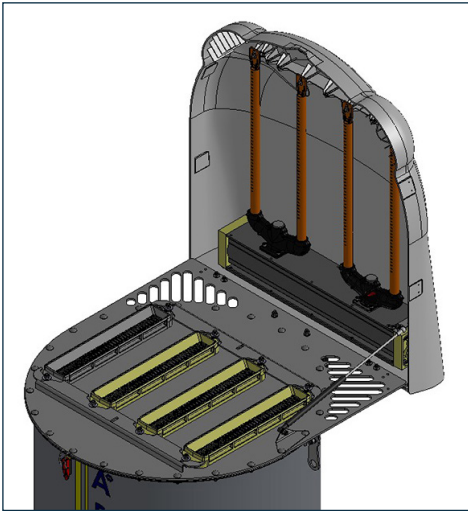

Open completely the cover.

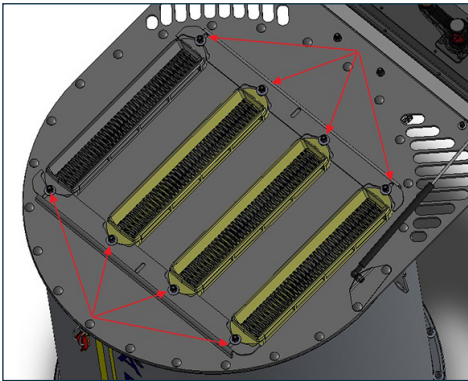

Slacken the **POLYPLEAT®** fixing brackets.

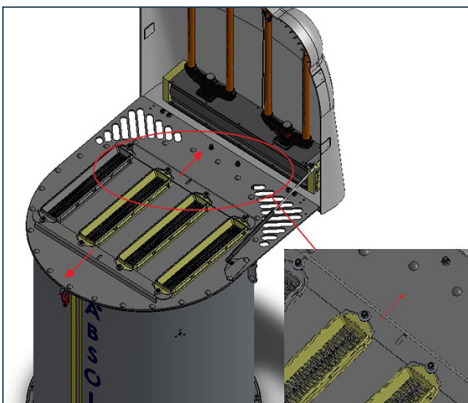

Remove the brackets to free the filter elements.

## 8.0 REPLACEMENT OF PARTS

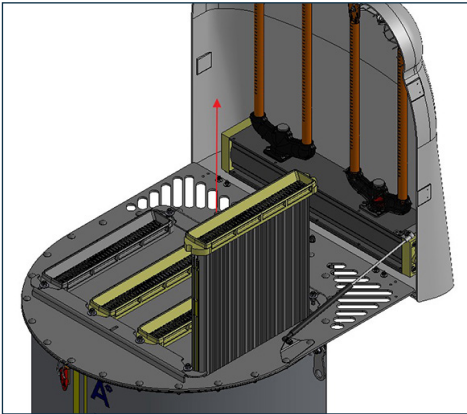

Pull out the filter element without damaging it.

For reassembly, repeat the above operations in reverse.

### 8.3 Replacing solenoid valve



#### Danger - Warning

Set the filter in safety condition (see glossary and terminology).

- 1) Remove coil (6) and connector (7) after removing the relative ring nut;
- 2) Unscrew the component (5) ensuring that the pin and spring inside does not fall and that the former slides perfectly in;
- 3) Inspect pin coupling area of components (4) to component (5) ensuring there are no impurities;
- 4) Remove the hexagonal socket head screws and washers that secure the valve cover (3);
- 5) Replace the diaphragm (1) and the spring (2);
- 6) Verify that the diaphragm (1) is positioned above the drain hole;
- 7) Insert the spring (2) into the recess of the cover (3);
- 8) Fit the new cover (if any) by checking that the spring is over the shoulder of the disc diaphragm and the cover is positioned over the vent hole.

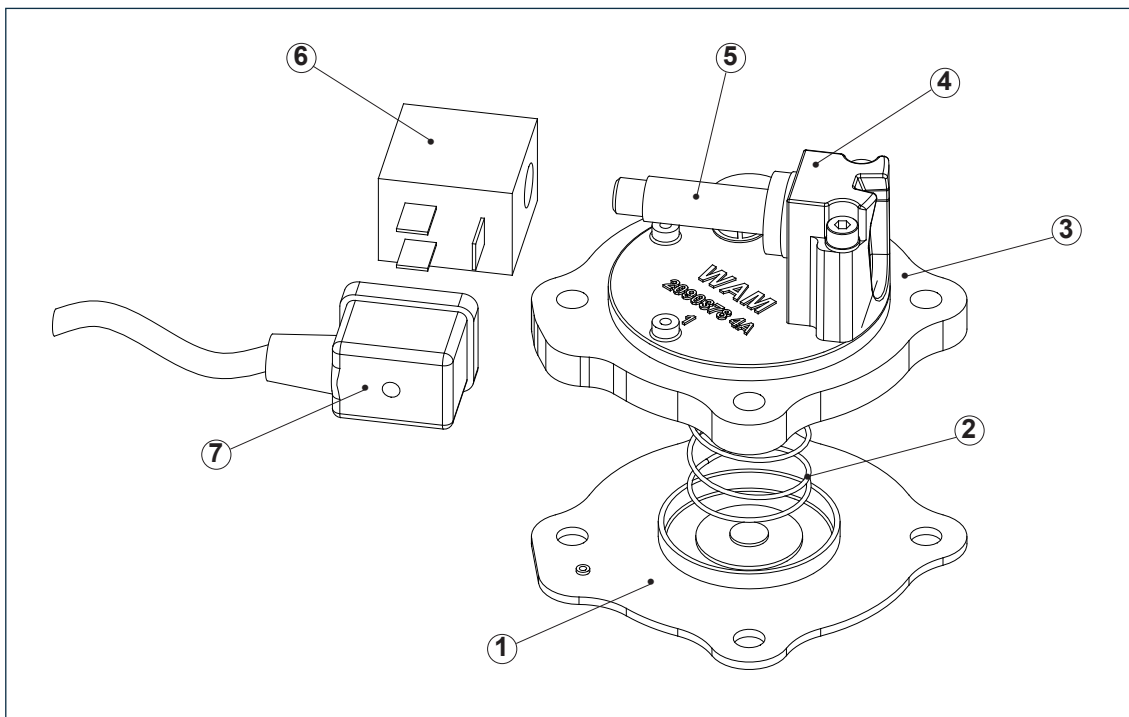

#### 8.4 Returning the equipment (the machine)

When returning the equipment (machine) use the original packaging if it has been preserved, otherwise fix the it on a pallet and cover it with nylon shrink-wrap, to protect it as best as possible from impact during transport. In any event, make sure there is no residue material inside the equipment (machine).

#### 8.5 Dismantling and disposal

Dismantling of the equipment (machine) must be entrusted to personnel specialized in these activities and equipped with adequate skills.

Dismantle the components of the equipment (machine) concerned; if necessary contact the Manufacturer for further information.

The components dismantled have to be separated on the basis of the nature of the materials of which they consist, in compliance with the laws on the matter of “differential collection and disposal of wastes”.

With reference to the WEEE Directives, electrical and electronic components, marked with a special symbol, have to be disposed off in authorized collection centres meant for the purpose.

Unauthorized disposal of “Waste Electrical and Electronic Equipment” (WEEE) is punishable with fines governed by the laws concerning the matter.

### 9.1 Trouble-shooting

Minor problems can be solved without consulting a specialist.

The following Table contains a list of the most common problems, the possible causes and possible remedies.

For particularly difficult actions which are not mentioned in the Table, contact the Manufacturer's Customer Service Department.



#### **Danger - Warning**

**Before carrying out any operation "set the equipment (machine) concerned in safety" (see "Glossary and terminology"), operate according to the indications on the "Operation and Maintenance Manual" and in accordance with and in compliance with the standards in force as regards health and safety.**

Problem	Probable cause	Possible remedy
Excessive differential pressure	1) Compressed air supply failure	1) Check the functioning of the compressor Check the condensation filters Check the presence of water and/or oil in the air tank of the filter
	2) Lack of air from the blowing pipes	2) Check the proper working of the electronic panel. Check the proper working of the solenoid valve. Check the proper working of the solenoid valve membrane
	3) Filter elements clogged	3) Operate the unit on empty and then remove all filter elements and replace damaged one
Dust in the clean area	1) Check for possibly damaged filter elements	1) Replace if damaged
	2) Check the seals	2) Replace if damaged
	3) Check if the filter elements are housed correctly in their seat	3) Install again, in case
Solenoid valve continuous blowing	1) Check the proper working of the coil	1) Switch on and off the compressed air supply to the filter 3-4 times. 2) Remove the component no. 6 after removing the relative ring nut. Unscrew the component 5 ensuring that the pin and spring inside does not fall and that the former slides perfectly in. 3) Inspect pin coupling area of components 4 to component 5 ensuring there are no impurities.

**9.0 INFORMATION REGARDING FAULTS**
*Electronic control panel*

No.	Problem	Solution
1	Not working	A) if the MS green LED does not flash 1) Check the power supply on terminal S1 2) Check the performance of the fuse (for replacement, use a fuse of the same type and having the same value)
		B) if the MS green LED flashes 1) Check if there is any enabling signal (verify if the contact S2 is closed) (CLEAN red LED On) 2) The control panel works properly when there is a power supply of 24 VAC on each pair of EV terminals (See- wiring diagram)

## 9.2 Check-list in case of fault

If you have been unable to solve the problem on the equipment (machine) even after having carried out the operations suggested in paragraph “Trouble-shooting” please contact the plant technician/installer/or the Manufacturer.

If technical assistance is required, in addition to the equipment data, the plant technician/installer or Manufacturer will also need information concerning the plant in which the equipment (machine) is installed, its installation and its working, for better identification of the problem that has occurred.

Obviously many of the checking operations which are requested have already been performed in the various steps during installation, testing and start-up of the equipment (machine) concerned.



### Danger - Warning

**Before carrying out any operation “set the equipment (machine) concerned in safety” (see “Glossary and terminology”), operate according to the indications on the “Operation and Maintenance Manual” and in accordance with and in compliance with the standards in force as regards health and safety.**

#### 1) *Information necessary*

- a) Description of problem.
- b) Photo showing the whole filter and how it is installed.
- c) Dusty air volume that flows in the filter.
- d) Does the filter start up without problems after long shutdowns?
- e) Is the outlet unblocked? Are there shut off valves that might prevent the evacuation?
- f) What is the duration of the operating cycle?

#### 2) *Checking the electrical part*

- a) Are voltage variations possible due to simultaneous start-up of various equipments?
- b) Is the plant equipped with a current generator?
- c) Measure the differential pressure of the filter.
- d) Check the electronic panel configuration and connection.
- e) What is the value of the voltage supply?
- f) What are the pause and working time of the cleaning system?

#### 3) *Checking the filter*

- a) Has the filter been assembled correctly?  
Are all the inspection hatches in closed position?
- b) Has the filter been fixed correctly?

#### 4) *Checking the dust*

- a) Material description?
- b) Bulk density? (kg/dm<sup>3</sup>)
- c) Particle size? (µm/mm)
- d) Moisture? (%)
- e) Flowability?
- f) Compressibility?
- g) Abrasiveness?

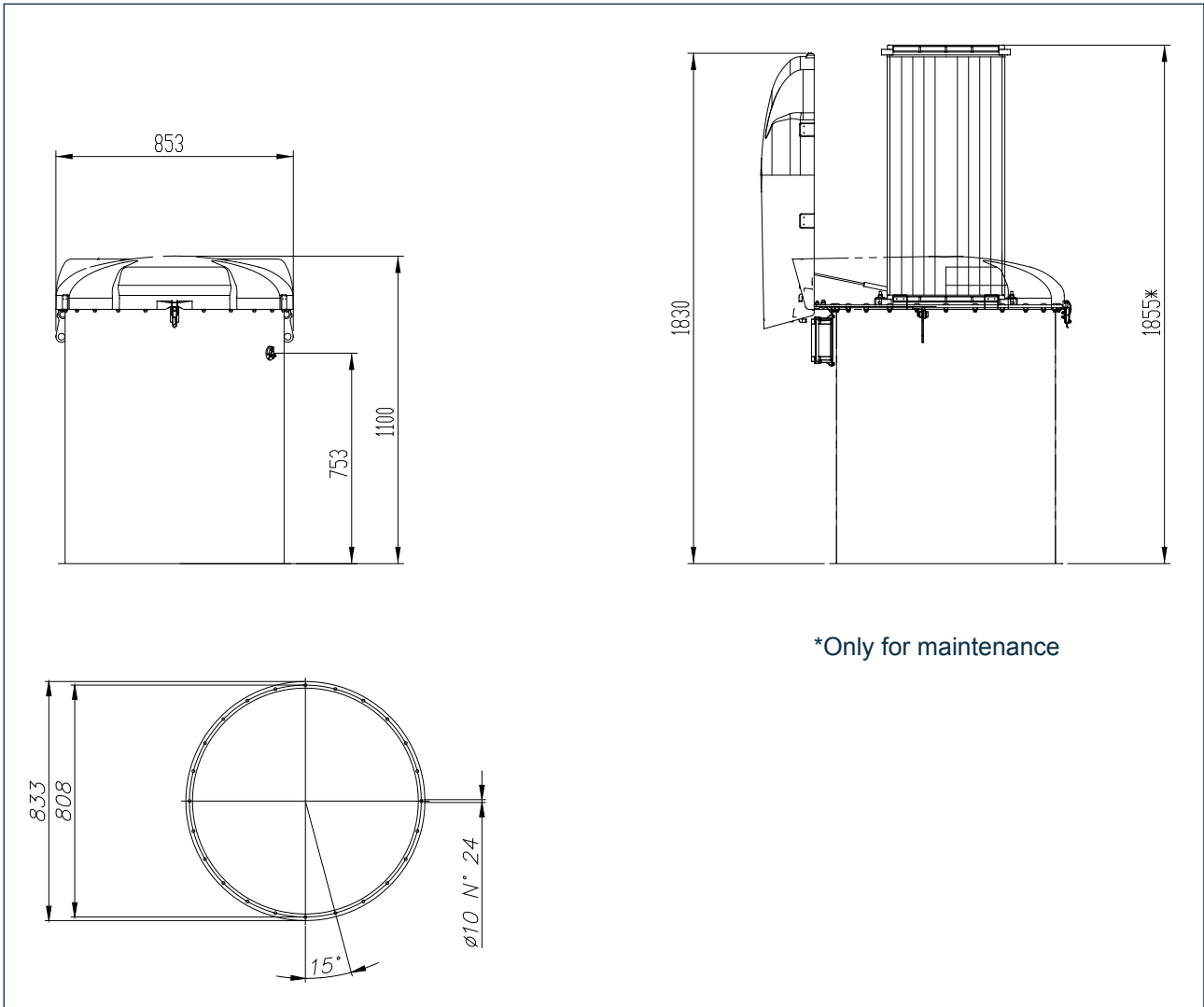

**10.1 Dimensions and weights**

	<b>ELEMENTS (n°)</b>	<b>FILTER SURFACE (m<sup>2</sup>)</b>	<b>SOLENOID VALVES (n°)</b>	<b>PESO* (kg)</b>
<b>SILAB14</b>	4	14	2	72
<b>SILAB24</b>	7	24	3	79

\* = the weight refers to the filter without the packaging

## 10.2 Filter elements

The filters **SILOTOP<sup>®</sup> zero** are provided with four or seven **POLYPLEAT<sup>®</sup>** type filtering elements, depending on the model chosen (see table on page 53).

These elements have parallelepiped shape and their dimensions are shown in the drawing below.

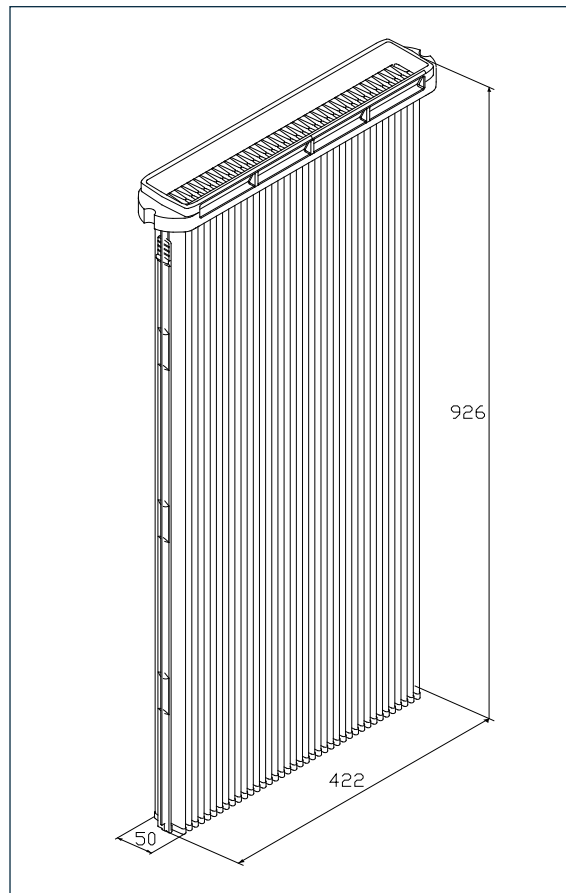

### 10.3 Cleaning system

SILOTOP® zero filter elements are cleaned by a reverse compressed air jet cleaning system.

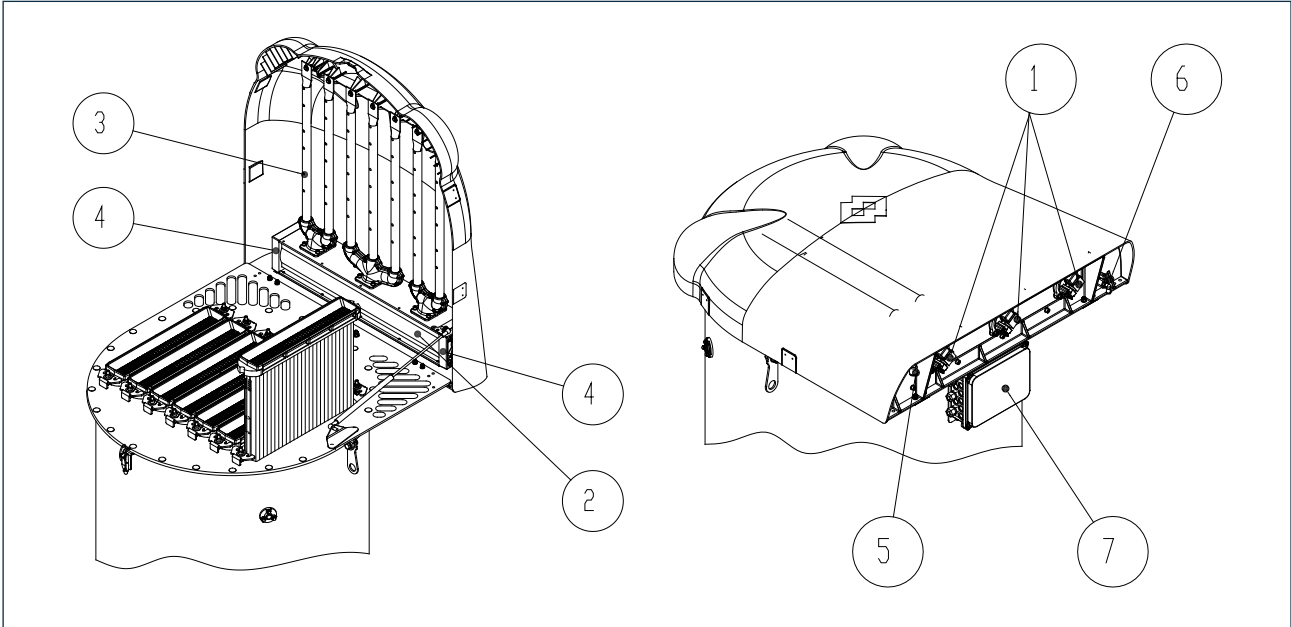

It consists of:

- Solenoid valve (1) fitted directly inside the compressed air tank (2);
- Engineering polymer blowing pipes (3);
- Aluminium air tank (4);
- Air inlet (5);
- Condensation drain tap (6).

The electronic control board (7) sequentially enables the activation of coils and solenoid valves to release the compressed air to the blowing pipes.

The filter requires connection to a compressed air pipe at minimum 5 bar and maximum 6 bar constant pressure. The air must be free of moisture and oil.

### 10.4 Accessories - Bottom ring

#### Bottom ring

Used to connect the filter to a hopper, silo etc. The ring is welded on the silo, hopper or cell and then bolted to the filter.

#### Finishing

- Carbon steel powder painted RAL 7001 (silver grey)

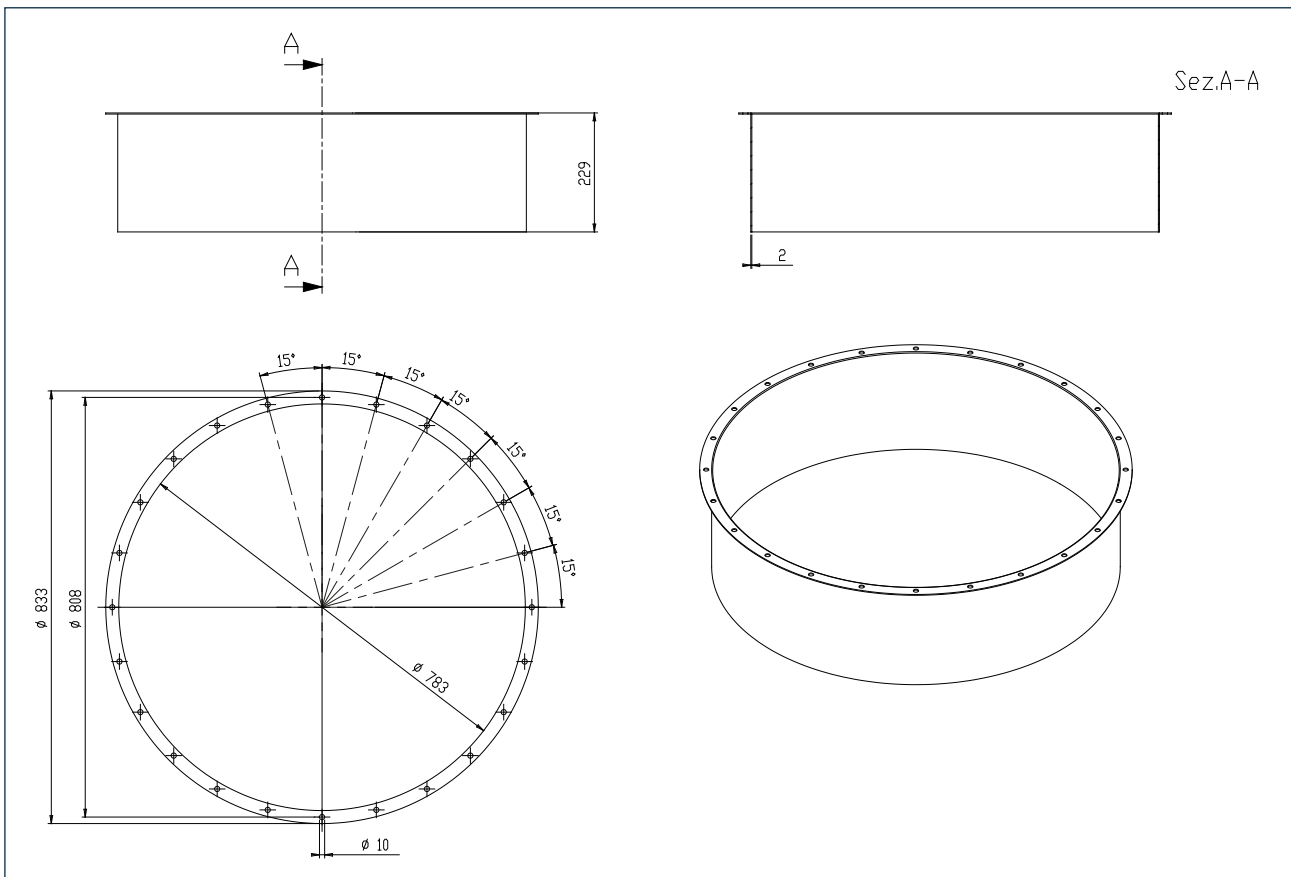

CODE Fe

U	F	N	8	0	0	1
---	---	---	---	---	---	---

CODE SS 304

U	F	N	8	0	0	2
---	---	---	---	---	---	---

### 10.5 Accessories - Emissions sampling connection kit

The emission sampling connection kit is used to convey all the air from the filter outlet into a single pipe.

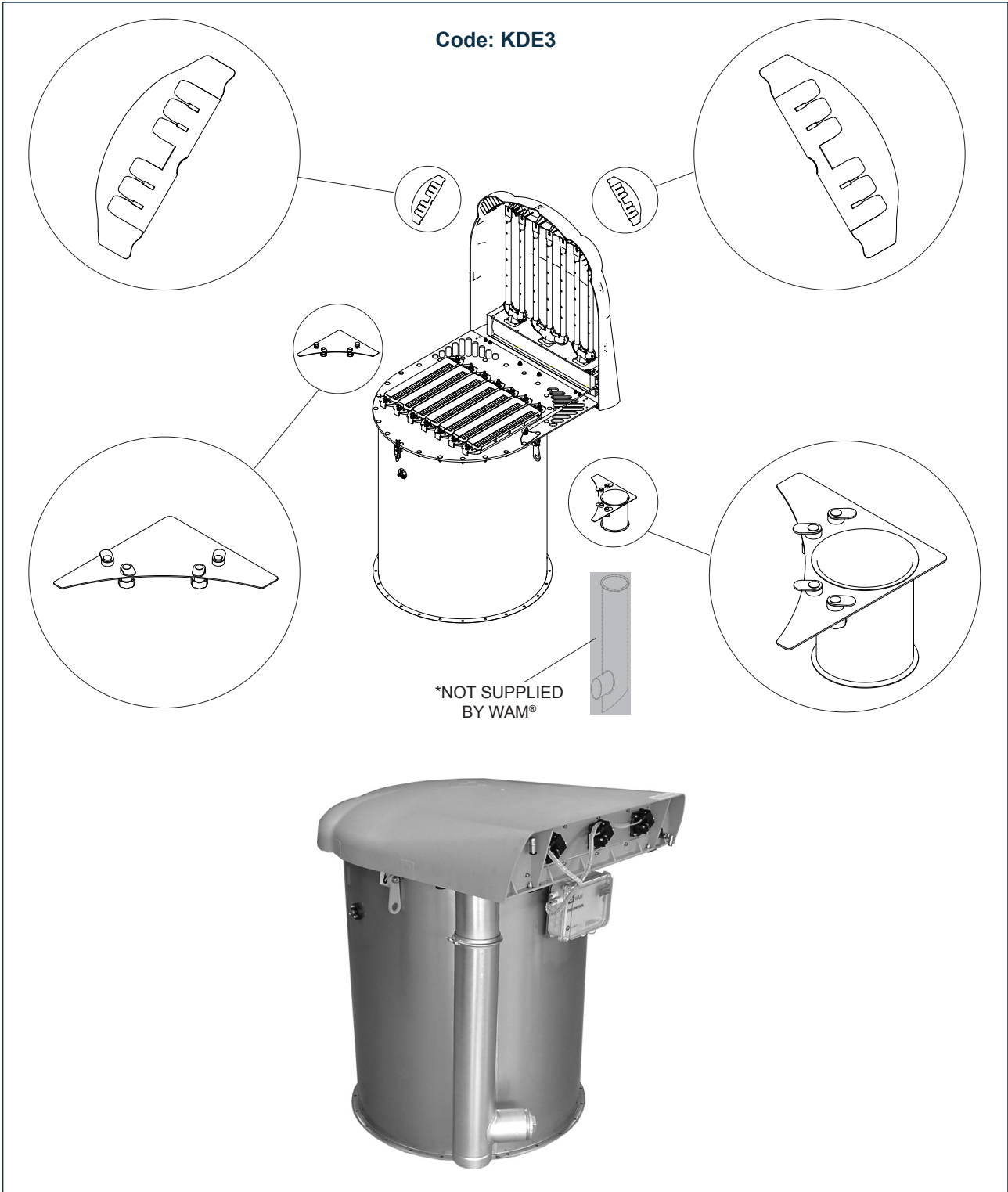

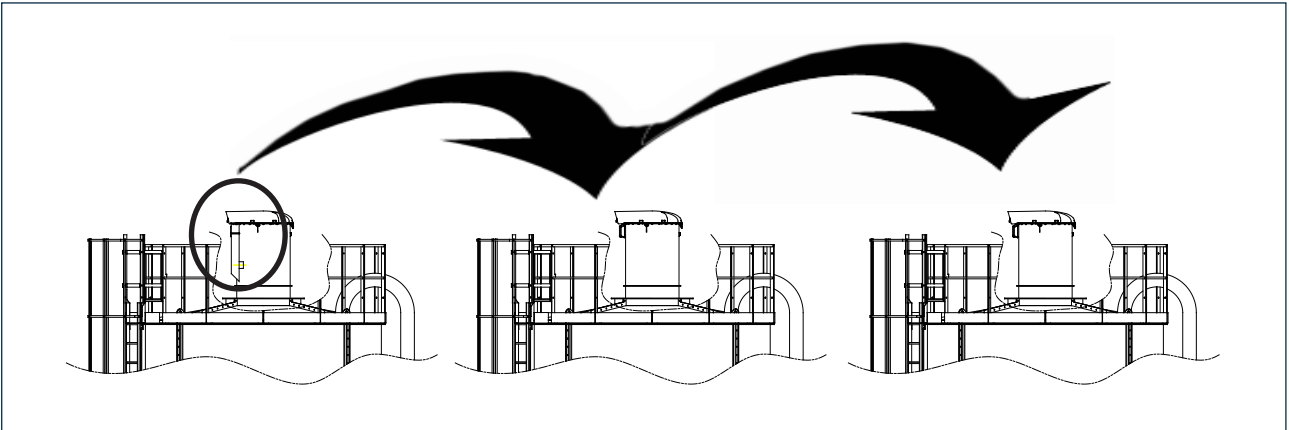

In case of plants with more filters, **WAM®** suggests using a single tube to be shifted from one filter to another. After making the measurement, remove the tube and air closure plates.

